

# INSTALLER'S MANUAL FOR THE "AHT" TAIL LIFT

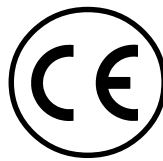

**HTK-500ST/AL**  
**HTK-750ST/AL**

**HTK-500ST/M**  
**HTK-750ST/M**

with underrun beam

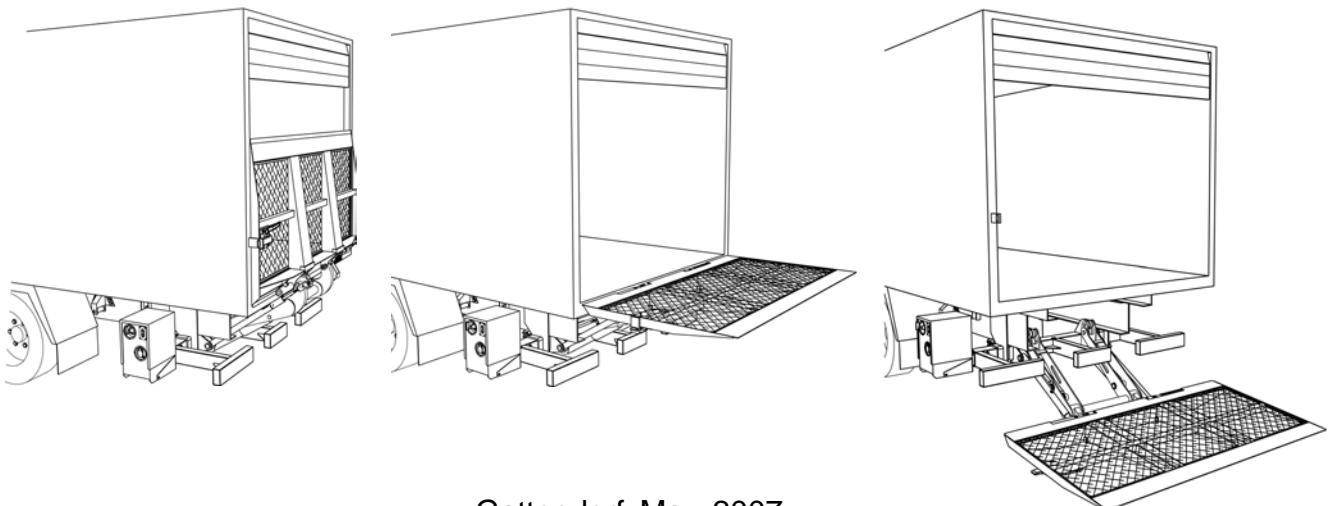

## **SERVICE QUALIFICATIONS TO INSTALL THE TAILGATE LOADER**

The installer should be well trained in the proper procedure for installing the AHT before beginning the installation.

Carefully read the manual **before starting to install** the AHT tailgate loader.

Only mature adults, age 18 and above, should install the AHT tailgate loader.

Installer should be well qualified for installing hydraulic equipment.

Installer should be well qualified for installing the electrical equipment.

### **INSTALLATION GUIDELINES**

- 1) Remove bumpers, lights, tool box etc. from rear of vehicle if necessary.
- 2) Cut and shape the body and chassis to fit the tailgate.
- 3) Fixing the mounting device on the truck body.
- 4) Remove the pin from platform bearing
- 5) Position the mainframe under the truck. Then displace the power pack.
- 6) Fix the mounting brackets onto the truck main frame.
- 7) Mount the power pack again.
- 8) Energize the power pack.
- 9) Remove the mounting devices and lower the hoisting unit for approximately 40cm.
- 10) Position the platform and install the joint plate, the spring, the tube and the pin at the platform bearing.
- 11) Lift up the lever arm and the closing cylinder and install the pins for lever arm - joint plate
- 12) Remove the tilting Lock.
- 13) Adjust the platform level.
- 14) Installing the platform lock.

## UNPACKING THE TAILGATE LOADER

A complete unit will be shipped on one pallet consisting of two main units:

- (1) Platform
- (2) Main frame with lifting arms, cylinders, power pack, mounting brackets, 2 button-remote-control and installation manual.

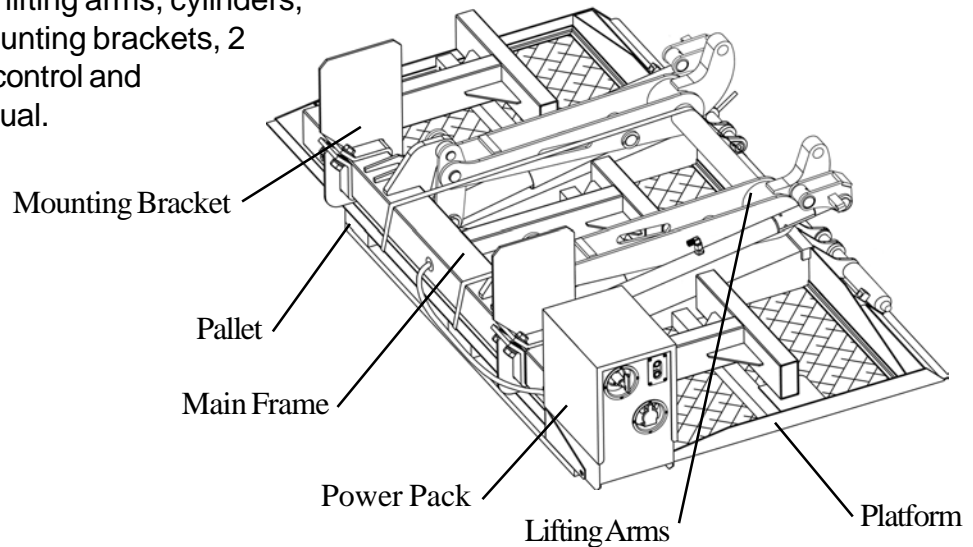

**CAUTION: Never lift the Main Frame with the hoisting unit at the stabilizer.  
(Lift cylinder will be damaged)**

**FORBIDDEN!!!**

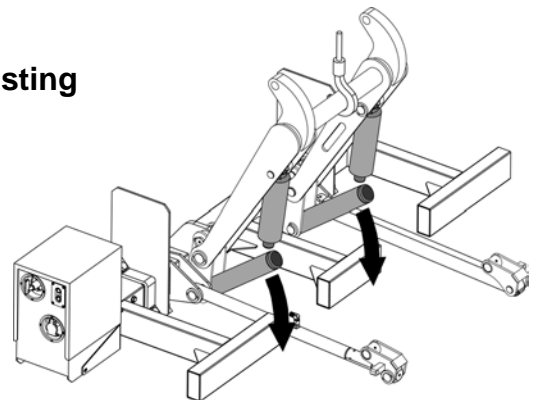

Always lift the complete unit evenly, as shown in the picture, being careful to raise the lift arms at the same time. Be sure the lift arms and the lever arms are secured.

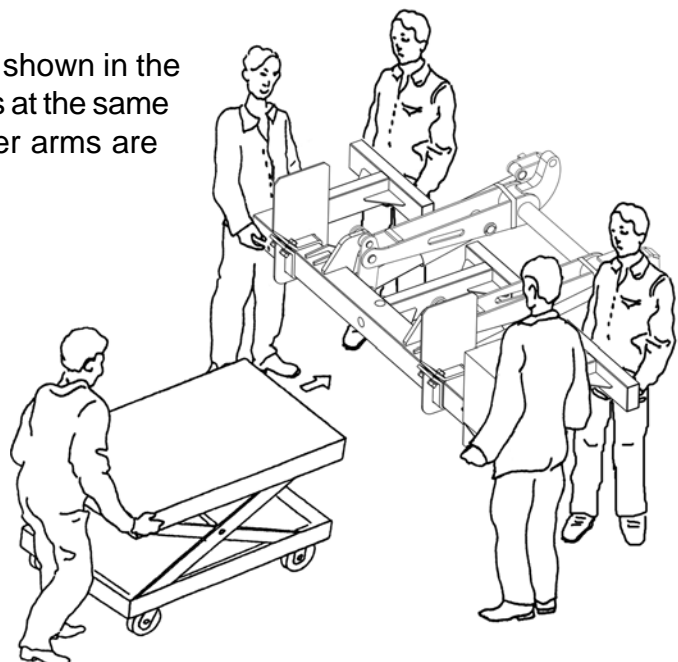

## PREPARING FOR INSTALLATION

Remove rear lights, bumper, tool box and spare wheel, if necessary.  
Disconnect the battery cable to prevent damage to the battery while welding.

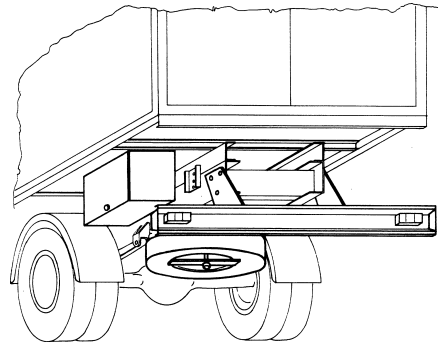

Remove any obstruction attached to the frame of the vehicle that would interfere with the installation. The mounting brackets will cover the mainframe and subframe.

**Subframe Tie-down**

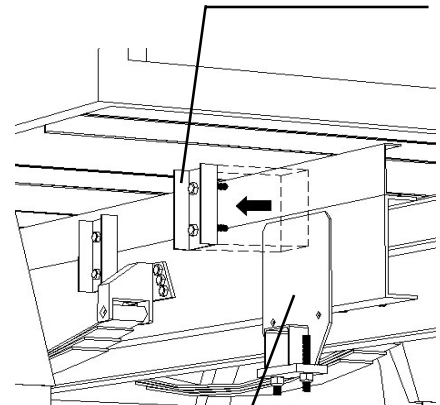

### Installing on a truck body with roll-up doors or without rear doors.

Cut out the rear of the frame, if necessary, as shown in the installation drawings.

#### Reinforce the cut outs.

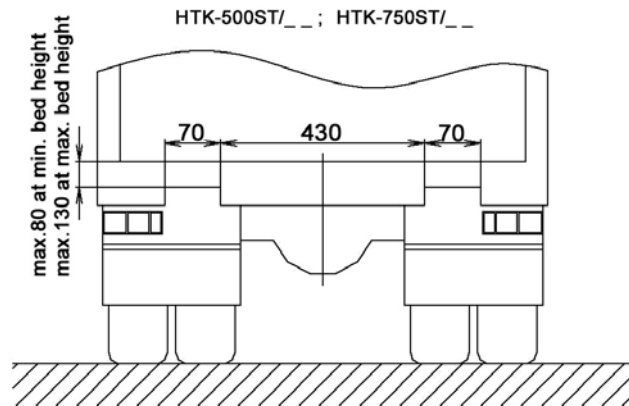

**Mounting bracket**

### Truck bodies with rear doors.

Refrigerated bodies with swing doors need an end profile, made from stainless steel, welded to the body as shown in the drawing, on the right.

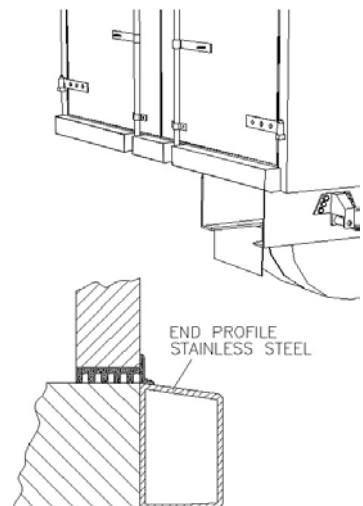

# INSTALLATION INSTRUCTIONS

## Installing the Mounting Device

### - Fixing the mounting device

Center the mounting device on the truck body floor.

Both mounting devices must make a contact with the truck floor end. Clamp both mounting devices on the truck body floor.

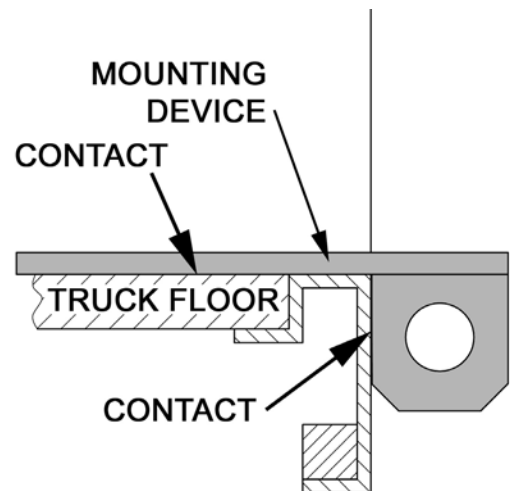
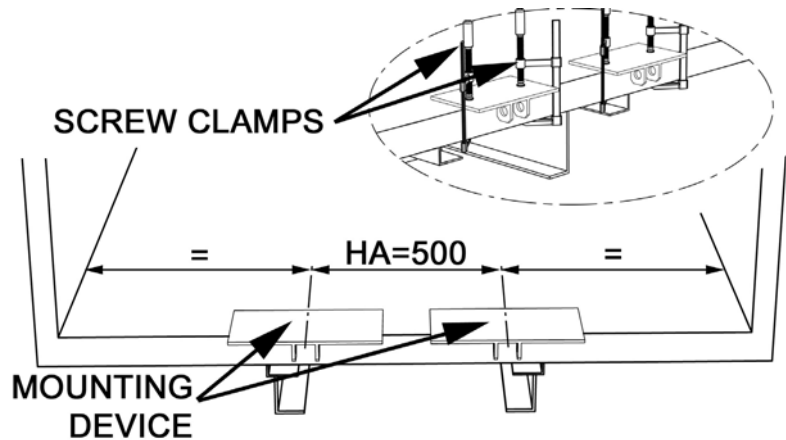

### - Platform Preparation

Before you can install the main frame you have to remove the 2 pins, the spring and the tube from the platform.

- 1) Remove the pin from platform bearing on both sides.
- 2) Remove the spring on the right side.  
Remove the tube on the left side.

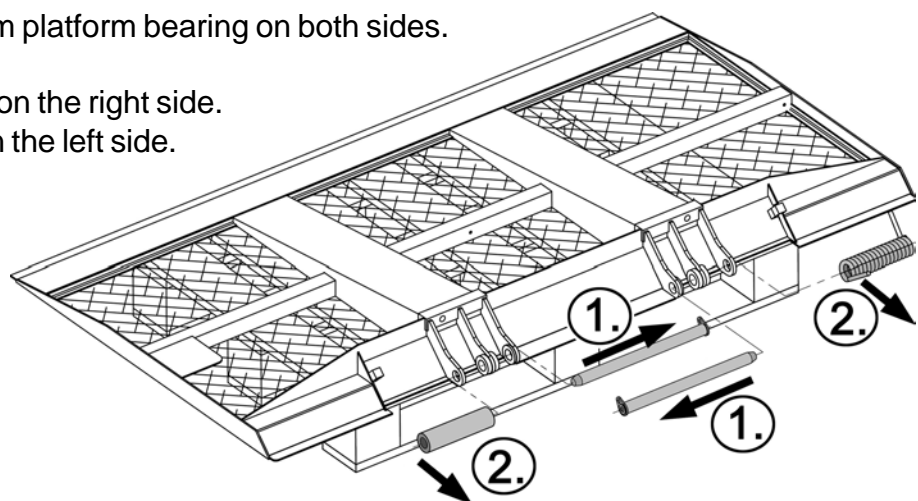

# INSTALLATION INSTRUCTIONS

## Position the tailgate unit

### - Position the main frame

- Install the mounting brackets on the main frame, but do not fix it.
- Place the main frame under the vehicle with lift arms attached using a floor jack, and raise main frame to its approximate final position.
- **Be sure to lubricate all pin surfaces before installing the pins.**
- Raise the hoisting unit to the mounting device, remembering that **the lift cylinders will come apart** if raised too high. (If necessary, raise the main frame closer to the vehicle chassis.)

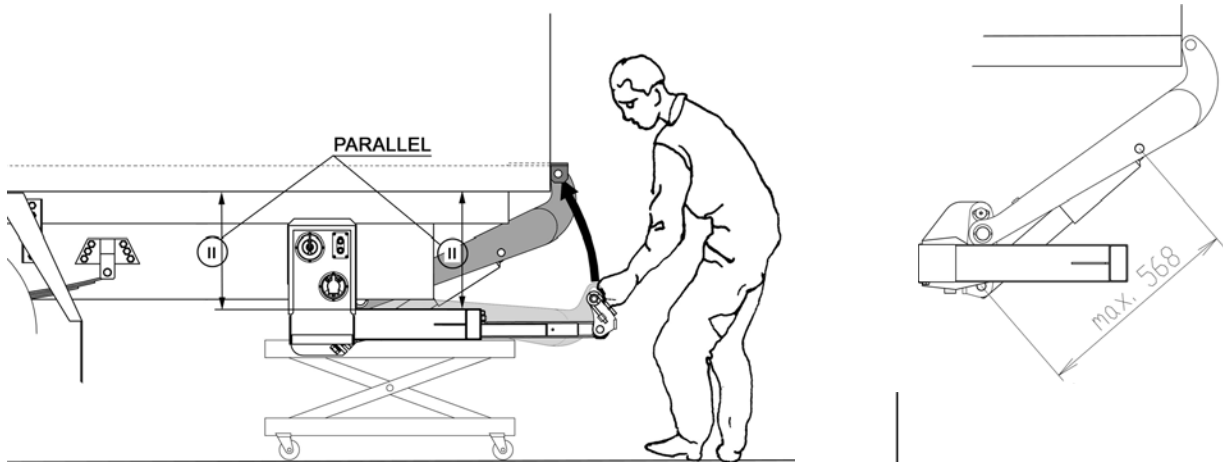

- Install pins (Lift arm - platform) between mounting device and hoisting unit.
- **The main frame must be parallel with the body.**
- **IMPORTANT: SEE "TAILGATE KINEMATICS" THE MAXIMUM AND MINIMUM MEASUREMENTS MUST BE KEPT.**

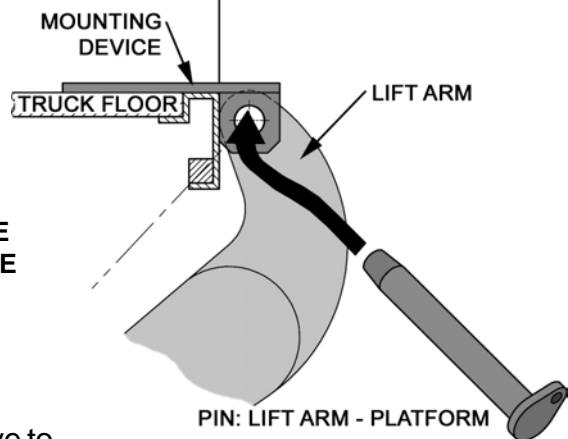

### - Displace the power pack

- Before you can fix the mounting brackets, you have to displace the power pack.

Loosen the 4 screws M10x25 on the power pack

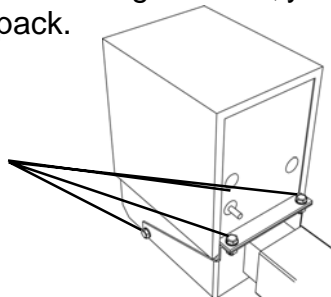

Now displace the power pack

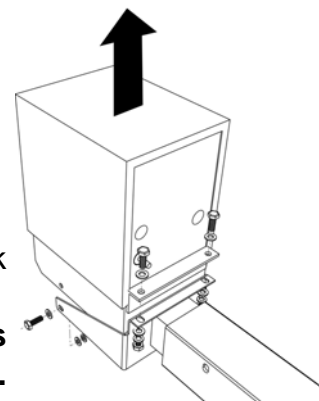

**It is not necessary to remove any hydraulic hoses, fittings and electric wirings.**

# INSTALLATION INSTRUCTIONS

## Position the tailgate unit

### - Install mounting brackets

- Place the mounting brackets to its exact final position.
- Clamp the mounting brackets on the truck frame.

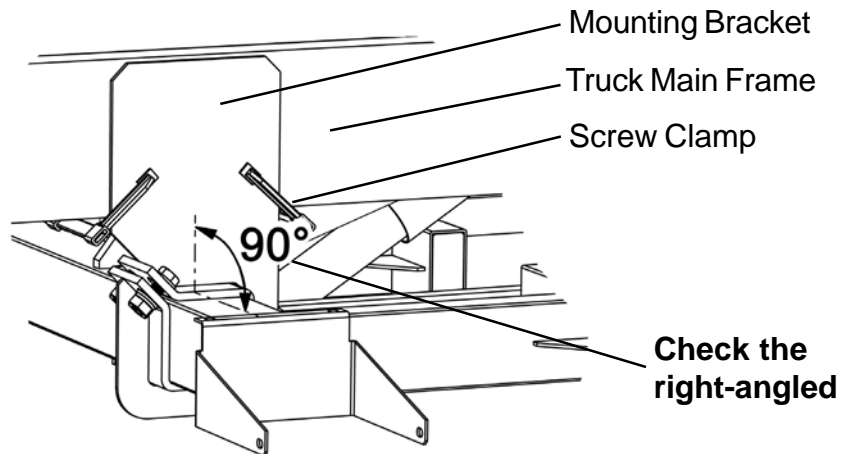

- Fix the mounting brackets on the main frame.
- Drill 16mm (5/8") holes into the chassis and mounting bracket.

Screw M16 (5/8") is 8.8 Strength (Grade 8)  
Max. Torque 195Nm (145ft lbs.)

Drill two holes in each bracket, put a bolt in each one and secure. Then drill the other holes.

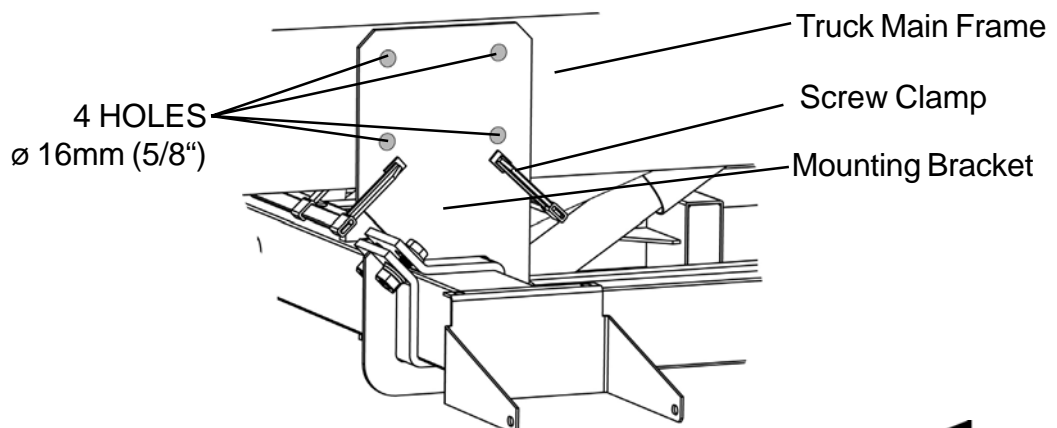

**NUMBER OF SCREWS PER MOUNTING BRACKET: 4 pieces  
M16x50**

- MOUNT THE POWER PACK AGAIN. FASTEN THE 4 SCREWS  
M10x25

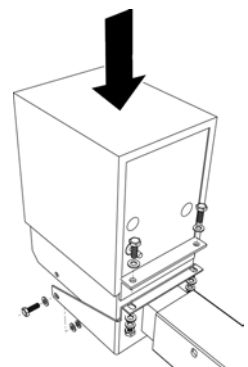

# INSTALLATION INSTRUCTIONS

## Energize the power pack

**CAUTION: REMOVE TRANSPORT FILLER CAP AND INSERT DIPSTICK:  
(There is no air hole in filler cap and the pump or reservoir will be destroyed)**

Be sure the vehicle and the liftgate are of the same current (12V or 24V).

Fuse is in the power pack. (12V = 25 Amp and 24V = 16 Amp).

Connect the **positive cable, directly from the battery, to the starter solenoid.** (min. 16mm<sup>2</sup>)

Connect the **negative cable, directly from the battery, to the motor ground.** (min. 16mm<sup>2</sup>)

Complete all other electrical work. (Connect all control switches)

**CAUTION: REMOVE TRANSPORT FILLER CAP AND INSERT DIPSTICK:  
(There is no air hole in transport filler cap and the pump or reservoir will be destroyed)**

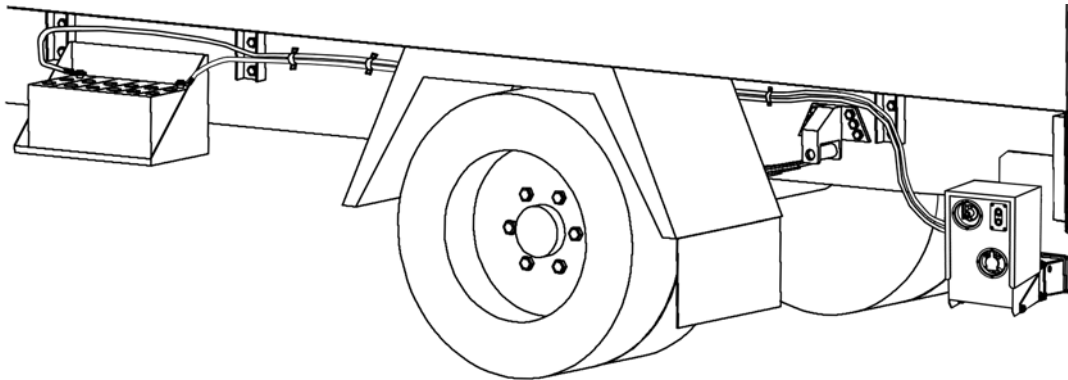

- Build in between Battery (+) and (+)-Cable the Main Fuse

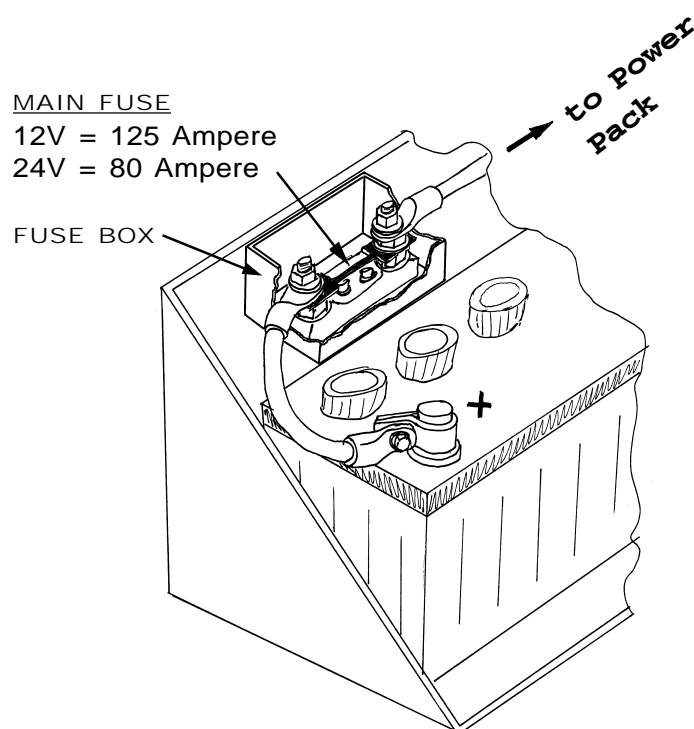



# INSTALLATION INSTRUCTIONS

## Correct wiring of the Power Pack

**NOTE:** All battery power leads must have a core area not less than 16mm<sup>2</sup> and be double insulated.

Connect both battery cables (+ and -) directly from the battery to the power pack.

**ATTENTION:** By fixing the battery cable on the starter switch, you must hold up the lock nut.

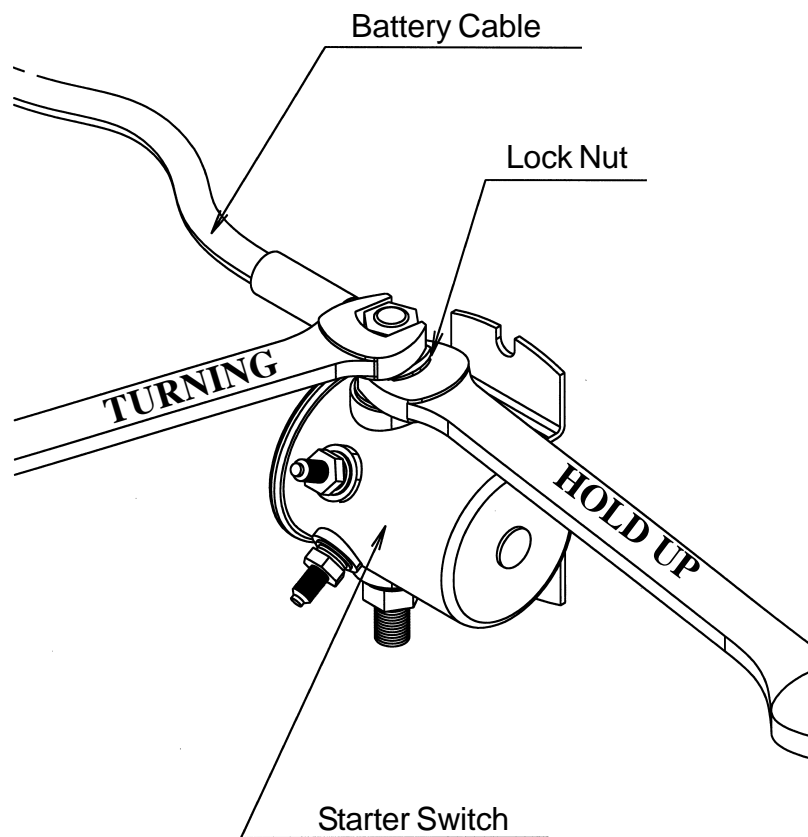

- \* Energize the power pack and actuate the valve to be sure they are operating properly.
- \* Please check the operating temperature regularly. It should not increase by more than -20°C to +70°C.
- \* Check a new power pack for leakage after a short period of time. Tighten any fittings that may be leaking.

# INSTALLATION INSTRUCTIONS

## Installing the platform

### - Remove mounting device

- Press the "UP"-Button to energize the hydraulic system until the pins for the mounting devices moves slightly.
- Remove pins between mounting device and lift arm.
- Remove screw clamps and mounting devices.

### - Installing the platform

- Press the "DOWN"-Button and push the hoisting unit manually downward in one time, to lower the hoisting unit approximately 40cm.

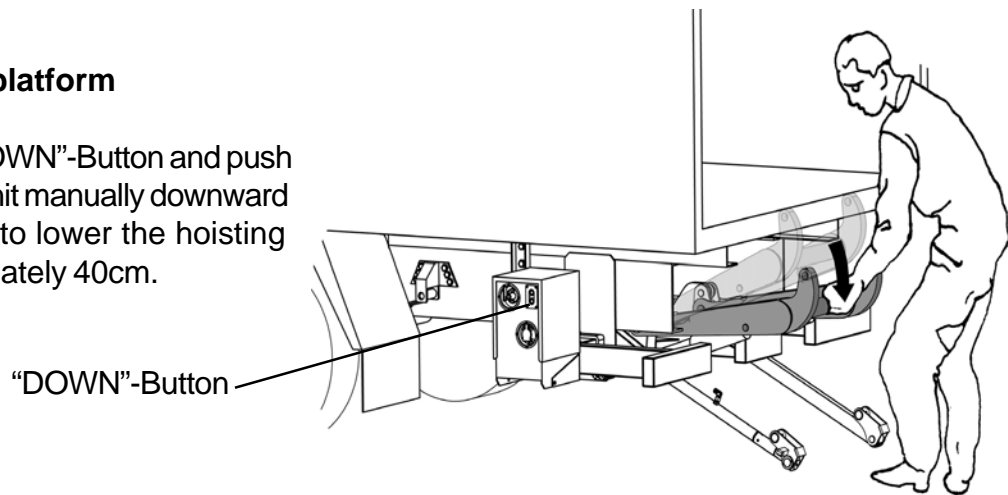

### - Position the platform

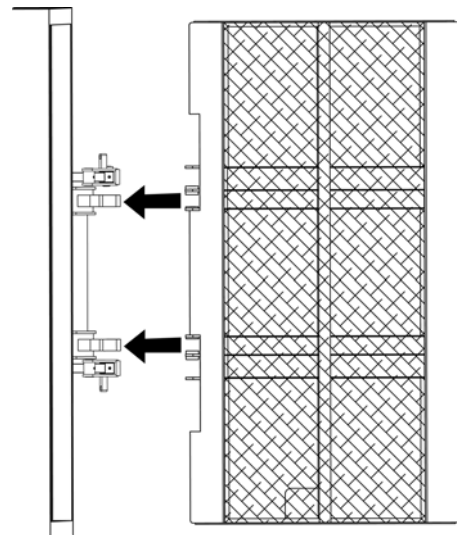
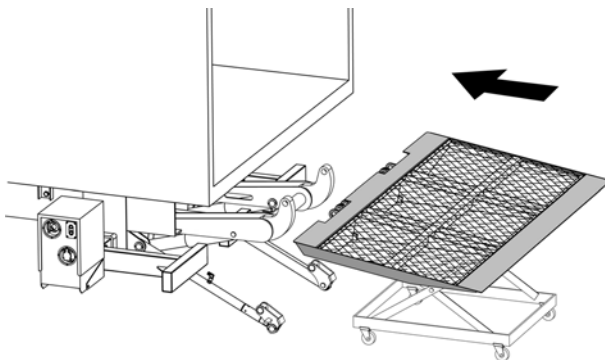

### - Remove the joint plate (on both sides)

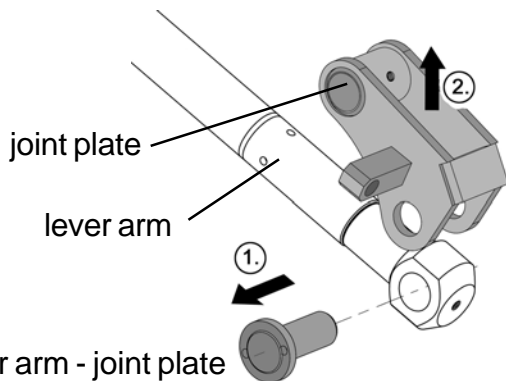

1) Remove pin between lever arm and joint plate

2) Remove the joint plate

# INSTALLATION INSTRUCTIONS

## Installing the platform

- Place the joint plate to the platform bearing (1) (on left side)
- Install the pin (lift arm - platform) from inside at the platform bearing. (2) (on left side)  
Move the pin only up to the joint plate. (3)

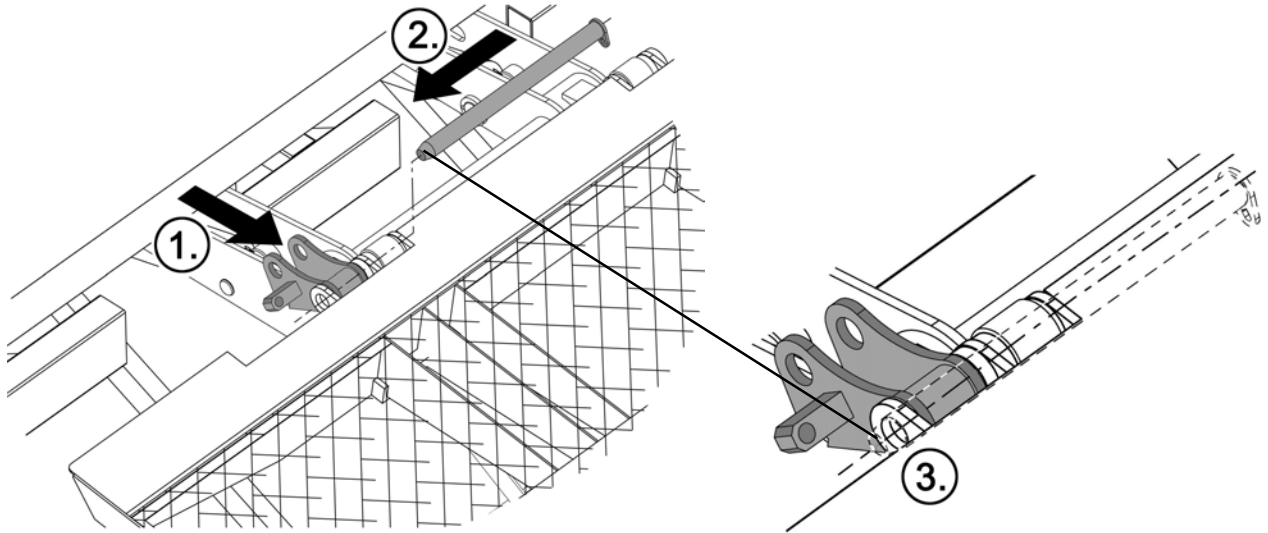

- Place the joint plate to the platform bearing (1) (on right side)
- Install the pin (lift arm - platform) from inside at the platform bearing. (2) (on right side)  
Move the pin only up to the joint plate. (3)

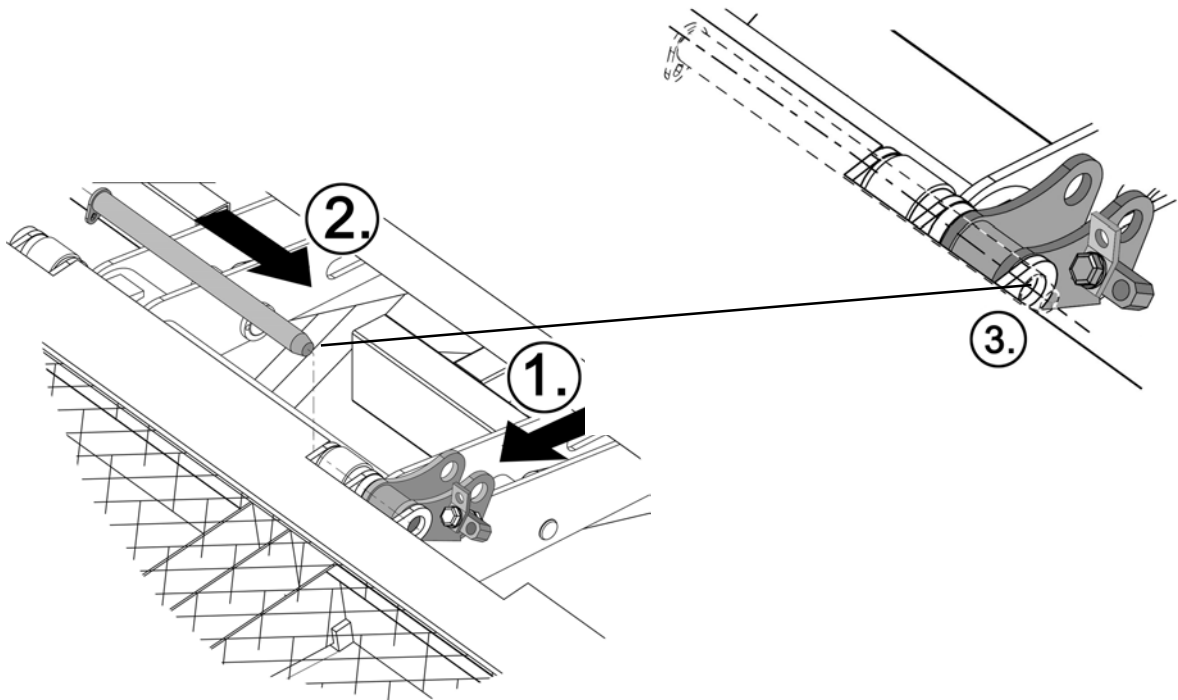

# INSTALLATION INSTRUCTIONS

## Installing the platform

- Install the torsion spring (only on right side)
- Put one end of the spring in the bearing of the joint plate and the other end in the bearing of the platform.
- Move the pin (lift arm - platform) to its final position and install the locking screw.

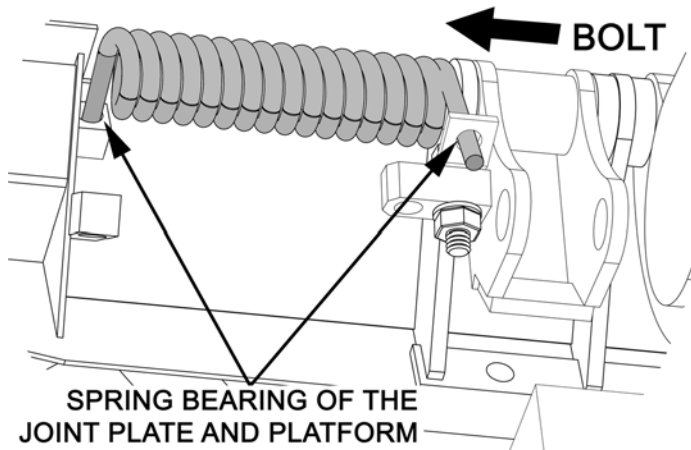

- Install the tube (only on left side)
- Move the pin (lift arm - platform) to its final position and install the locking screw.

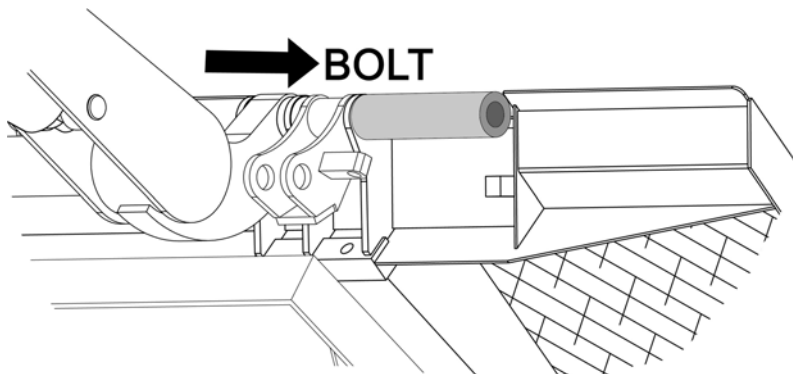

- If both pins (lift arm - platform) are installed and secured, manually close the platform (30°).

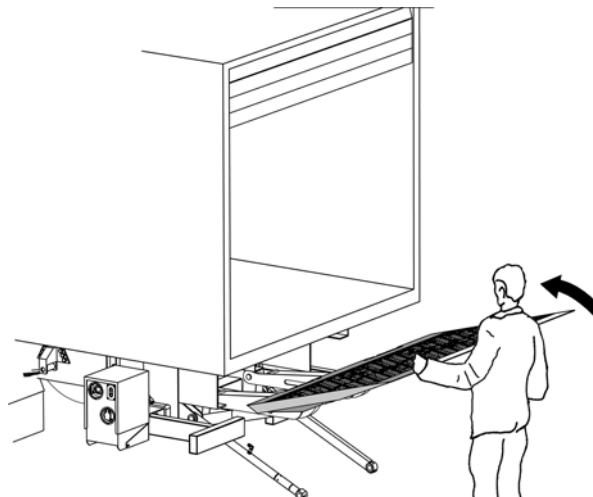

# INSTALLATION INSTRUCTIONS

## Installing the platform

- Now lift up the lever arm on the right side and the platform closing cylinder on the left side to the joint plate.

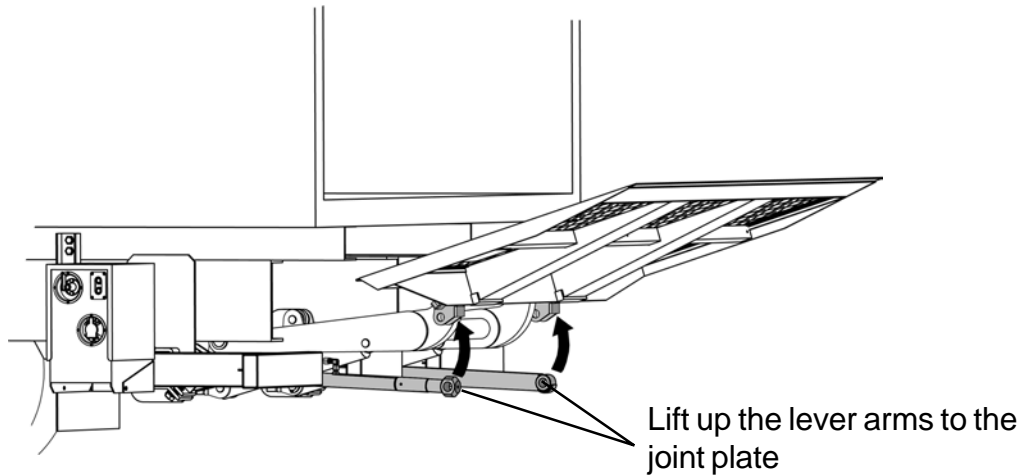

- Install the pin on the right side (lever arm - joint plate) and secure it.

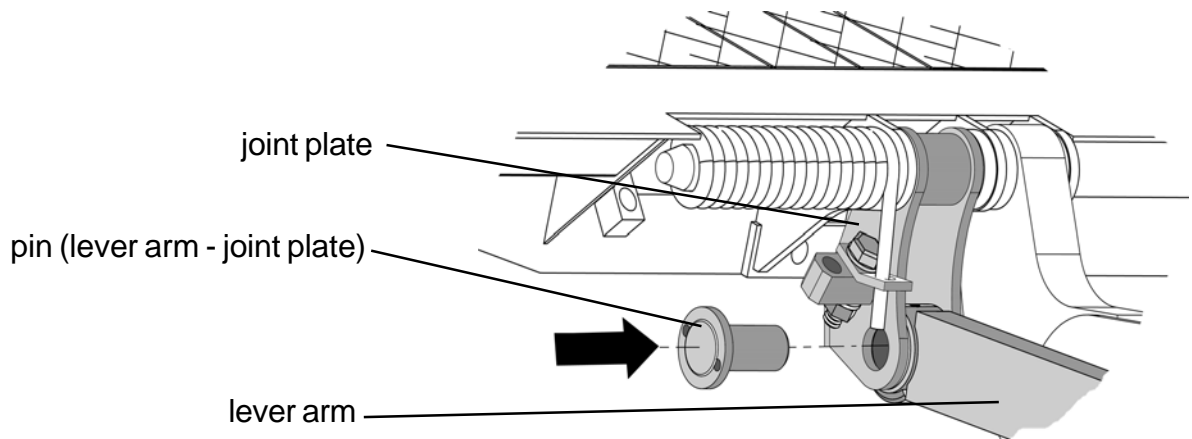

- Install the pin on the left side (lever arm - joint plate) and secure it.

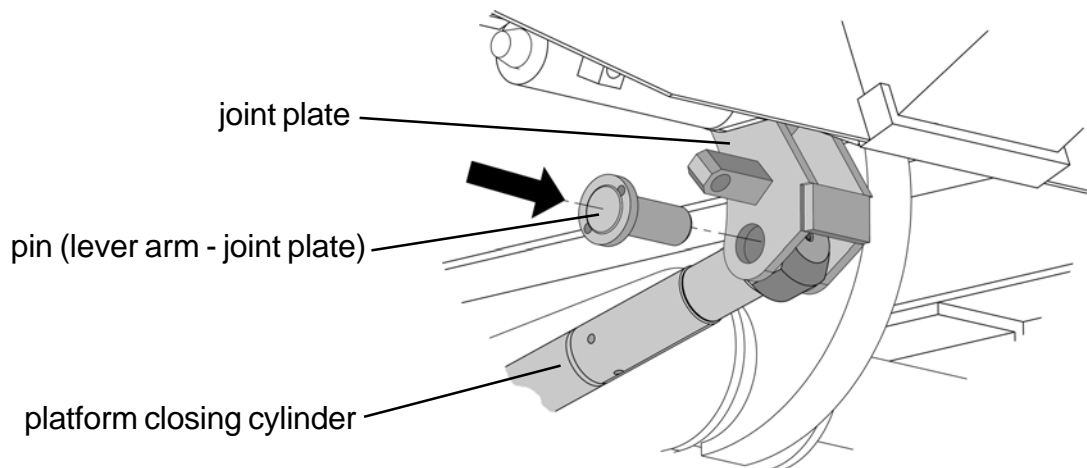

# INSTALLATION INSTRUCTIONS

## Remove tilting lock

- The platform installation is now complete. Open the platform.

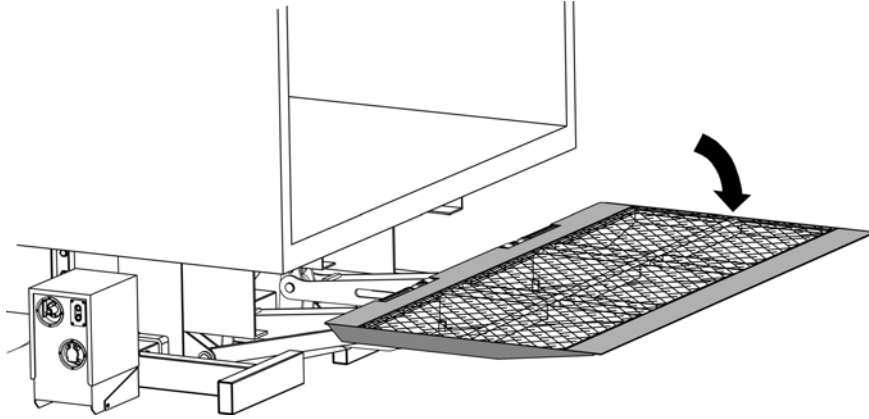

- Remove Tilting Lock

The tilting lock prevents the automatic leveling from working until the installation is complete. It is the last thing to remove.

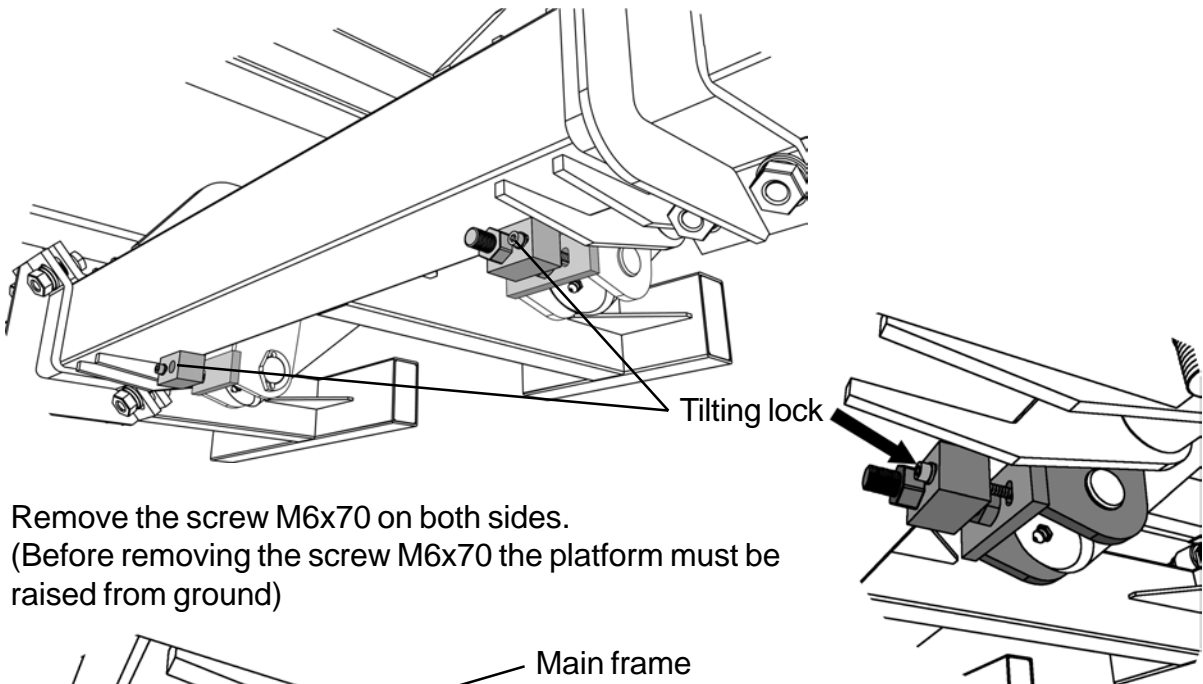

- Remove the screw M6x70 on both sides.  
(Before removing the screw M6x70 the platform must be raised from ground)

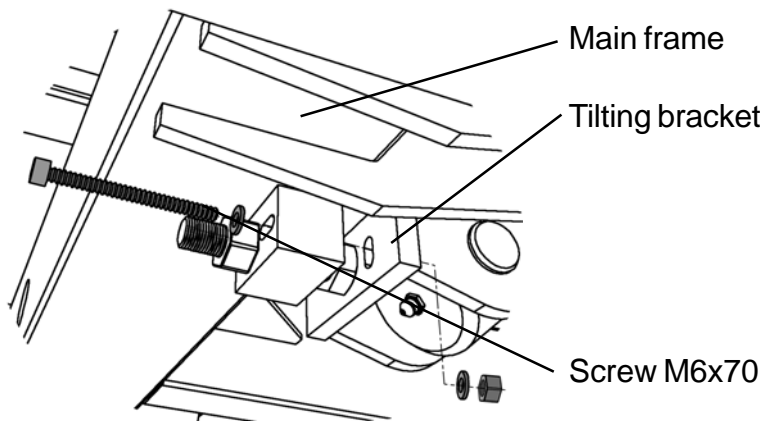

# INSTALLATION INSTRUCTIONS

## How to adjust the platform level

- Lower the platform to ground level. (Do not tilt the platform to ground)

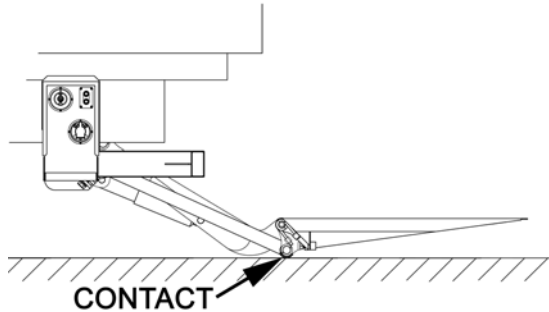

- Loosen the locking nut. (on both sides)

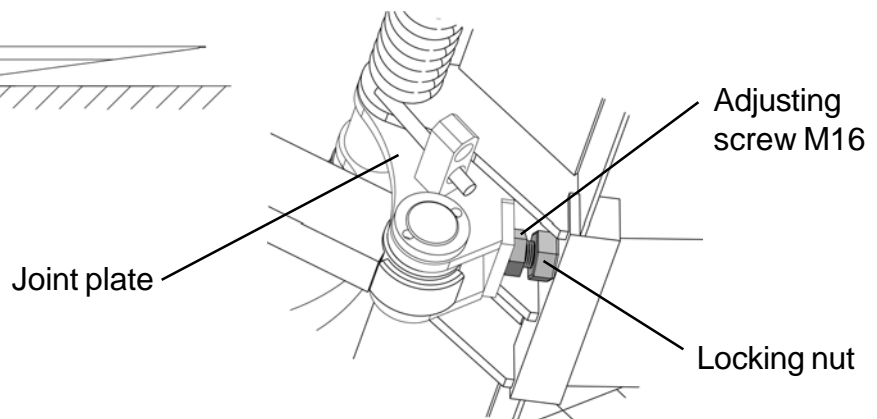

- Turn the adjusting screw clockwise for lower the platform tip (on both sides)

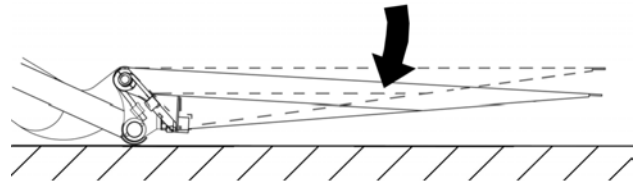

- Turn the adjusting screw anti clockwise for raise the platform tip (on both sides)

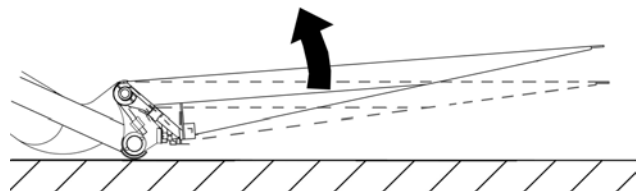

- Check the correct adjustment of the adjusting screws  
On lower position, the both adjusting screws must have contact with the joint plate.

**OK**

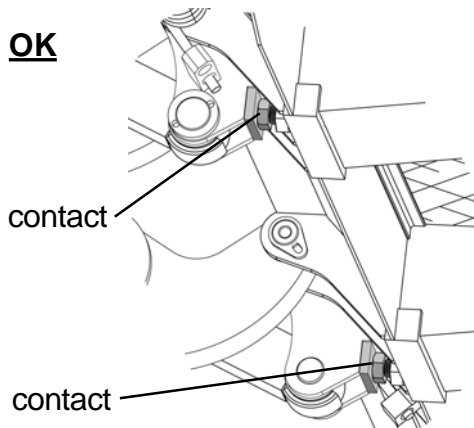

**WRONG**

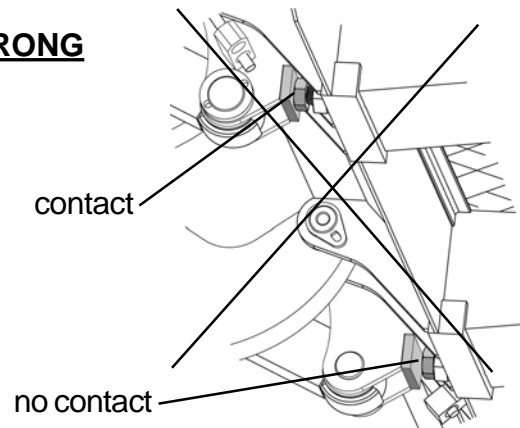

- If the platform level is correct, fasten the locking nut. (on both sides)

# INSTALLATION INSTRUCTIONS

## Installing the platform lock

### - Installing the platform lock

- Be sure the platform is in its uppermost position (at vehicle bed level) and closed.
- Weld or bolt the lock hook to the vehicle body.

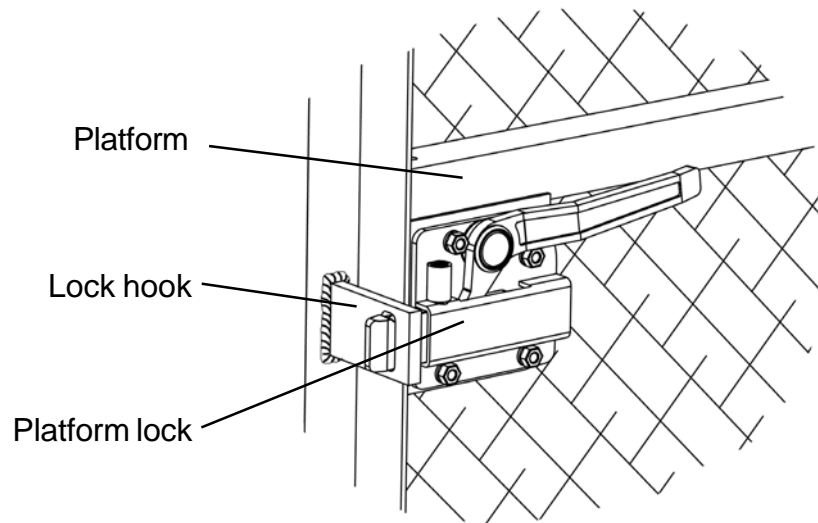



**MODEL: HTK-500ST/M**

**BASIC DIMENSIONS**  
for Liftarm: L=750mm and Platform: L=950mm

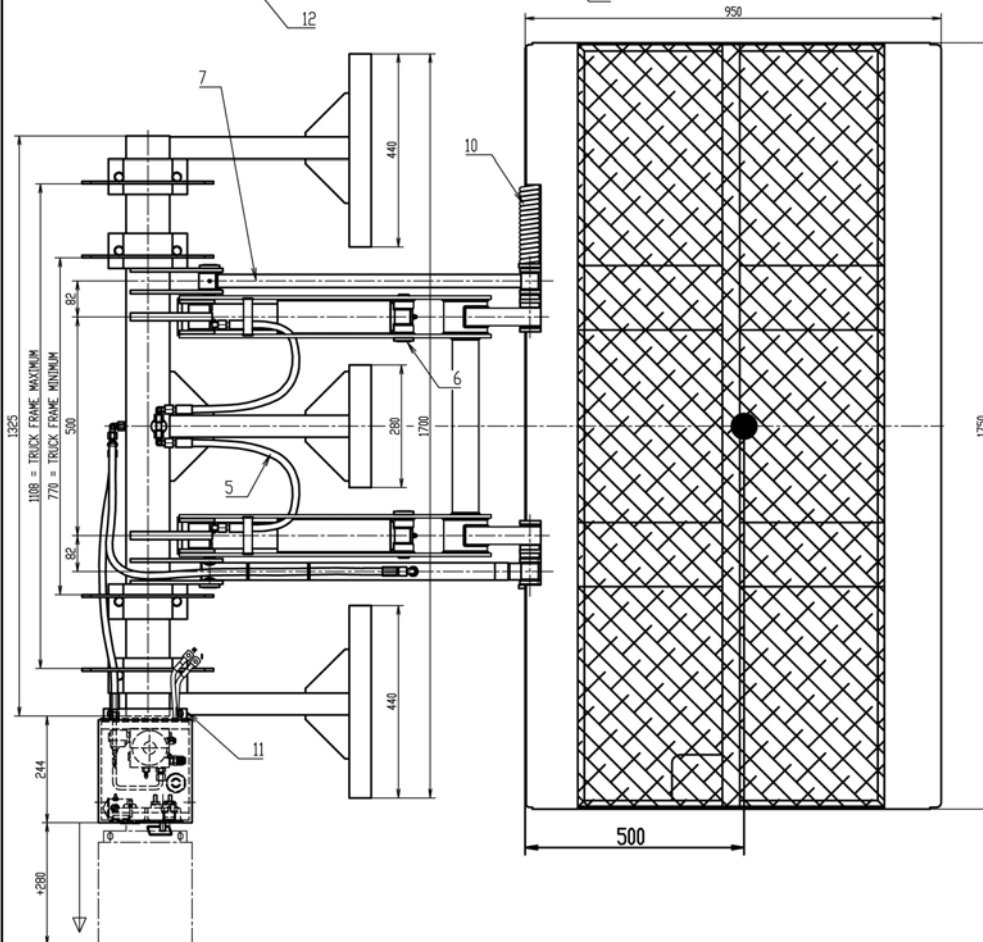
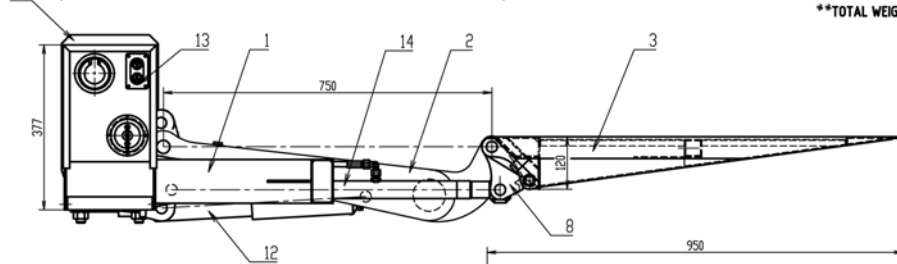
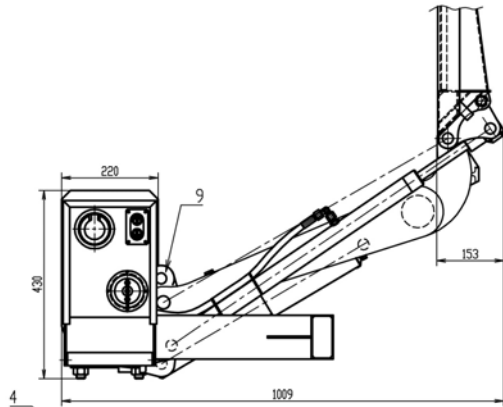

PART No.	PCS.	DESCRIPTION	DRAWING No.	WEIGHT
1	1	CROSS BEAM WITH UNDERRUN BEAM	ATK-750ST-1UFS-MT/500	415kg
2	1	LIFT ARM	ATK-750ST-2L/500	310kg
3	1	PLATFORM WITH MESH 1750x950	HTK-750ST-3SG	66.5kg
4	2	MOUNTING BRACKET	ATK-750ST-4	14.6kg
5	1 SET	HYDRAULIC HOSE, OIL, * and - CABEL, ADDITIONAL PARTS	HTK-750ST-5	8.0kg
6	1 SET	BOLT ASSEMBLY	HTK-750AL-6	6.6kg
7	1	LEVER ARM	ATK-750ST-7L	4.0kg
8	2	JOINT PLATE	ATK-750AL/G-8L(R)	1.0kg
9	2	TILTING BRACKET	ATK-750AL/G-9L(R)	1.7kg
10	1	TORSION SPRING	ATK-750-10R	1.2kg
11	1	SLIDING BRACKET FOR POWER PACK	UTK-750ST-14	5.7kg
12	2	LIFT CYLINDER Ø35 with mech. hose burst valve	HZ-500AL-35M *	5.4kg
13	1	POWER PACK	MHW-TK-500	9.8kg
14	1	CLOSING CYLINDER	PS-20/140	3.0kg
1	1	[CROSS BEAM WITHOUT UNDERRUN BEAM ATK-750ST-1-MT/500 24.7kg]**		

\* OPTION: with electrical hose burst valve (HZ-500AL-35E)

**TOTAL WEIGHT 200.0kg**

**\*\*TOTAL WEIGHT WITHOUT UNDERRUN BEAM 183.5kg**

© Copyright by AHT 2006

MODEL: HTK-500ST/M

# TAILGATE KINEMATICS

for Liftarm: L=750mm and Platform: L=950mm



## MINIMUM MEASUREMENTS

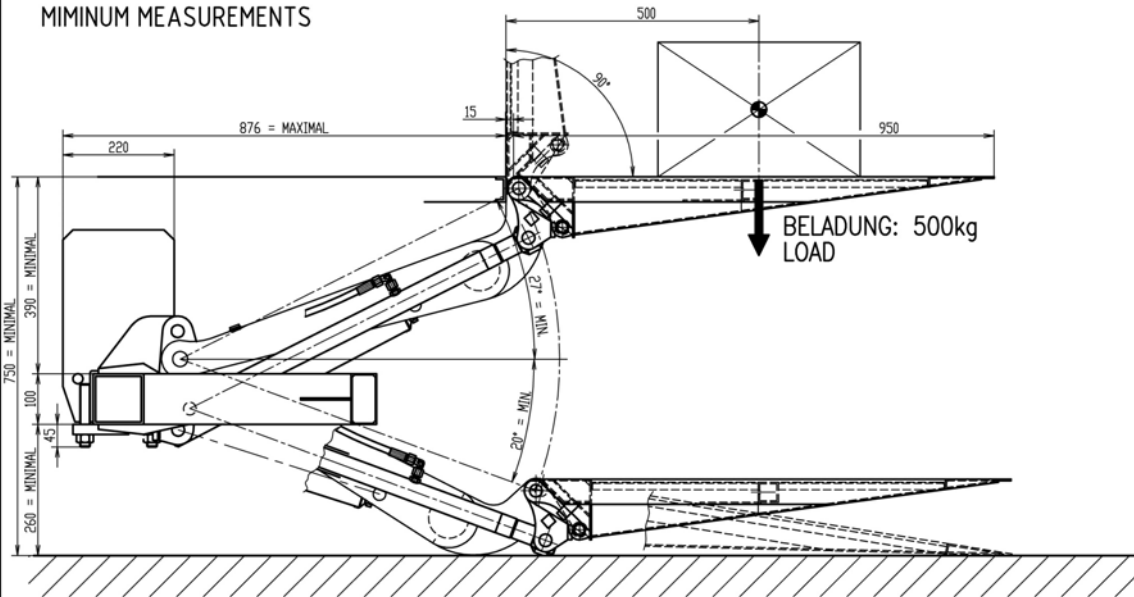

## MAXIMUM MEASUREMENTS

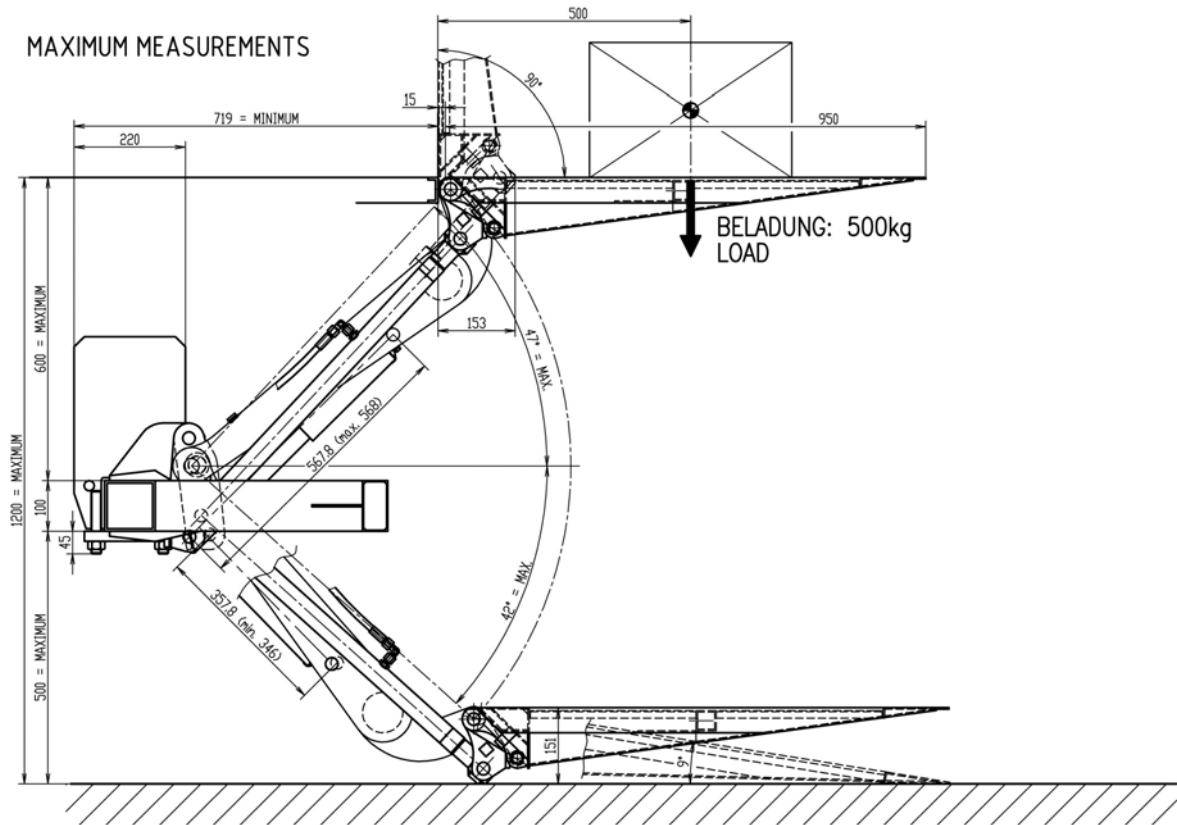

© Copyright by AHT 2006

**MODEL: HTK-500ST/M****TAILGATE SPECIFICATIONS**

for Liftarm: L=750mm and Platform: L=950mm

**STANDARD SPECIFICATIONS**

CAPACITY kg	<b>500kg at 500mm Gravity Center</b>
NOMINAL PLATFORM SIZE mm	1750 Width x 950 Length x 120 Depth
INSTALLED WEIGHT kg	200
FITTING REQUIREMENTS mm	1200 Max. Height Unloaded 750 Min. Height Loaded 720 Min. Underbody Clearance Required*
ADDS TO VEHICLE mm	153

**OTHER SPECIFICATIONS**

<b>WEIGHT</b>	Unit & Cylinder kg	192	
	Installation Kit kg	8	
<b>PLATFORM</b>	Platform with Mesh	Welded Steel Construction (Galvanized)	
	Mesh	~62x25; Cross-Section 6x3	
	Trolley Stops	No	
	Platform Angle	16.0% or 9'	
<b>LIFT ARM</b>	Construction	2x8mm Steel Plate 40mm Steel Plate on the Platformside	
	Arm Depth mm	96	
	Arm Length mm	750	
	Re-Bushable	Yes	
	Overall width mm	596	
	<b>MAIN FRAME</b>	Construction	100mm x 100mm x 5
	Bracket Thickness mm	6	
<b>PINS</b>	Material	Ø25; Ø30mm Hard Chrome Plated	
	Grease Nipples	Yes	
	Pinlock and Screws	Stainless steel	
<b>BUSHES</b>		Steel Teflon Coated	
<b>HYDRAULIC</b>	Power Pack	M.H.W.	
	Weather Proof Alum Enclosure and Sound Proof	Included	
	Motor Size	0.8kW	
	Lift Cylinders: Quantity	Quantity	Two (2) Lift
		Size	Ø35mm; max. Stroke:222mm
		Quality	Cylinder are all Aluminium Piston are all Ceramic plated and Teflon Sealed for Long Life
	Hose Burst Valve	one mechanical hose burst valve on each Cylinder	
	Closing Cylinders: Quantity	Quantity	One (1) Closing
		Size	Ø20mm; max. Stroke:140mm
		Quality	Cylinder Tube is made from Aluminum Piston is made from Steel; Hard Chrome plated and Teflon Sealed for Long Life
	Leak Proof Check Valve	Included	
	Hoses	Ø6mm (1/4") Thermo Plastic 2pcs. L=750mm; 2pcs. L=1000mm	
	Flow Control	Pressure Compensating	
Oil Type	Hydraulic Oil 22cSt		
<b>OPERATION</b>	Lift Operation	Power up/Gravity down	
	Tilting Operation	automatical mechanical Tilting on the ground floor	
	Closing Operation	automatical hydraulic Closing at Truck Floor Level	
	Locking Device	Platform Lock	
<b>CONROLS</b>	Battery Isolation Switch	Integral to Power Pack	
	Fixed Control	2 Button on Power Pack	
	Removable Remote Push Button	2 Button Hand Held c/w 3m Lead	
	Safety Plug	Yes	
	Base	Yes (Flush Mounted)	

© Copyright by AHT 2006

\* Subject to Vehicle Type &amp; Floor Height

MODEL: HTK-500ST/M

# TAILGATE KINEMATICS

for Liftarm: L=750mm and Platform: L=950mm



## CENTRE OF MASS FOR HTK-500ST/M IN TRAVELING POSITION

MEASUREMENTS:

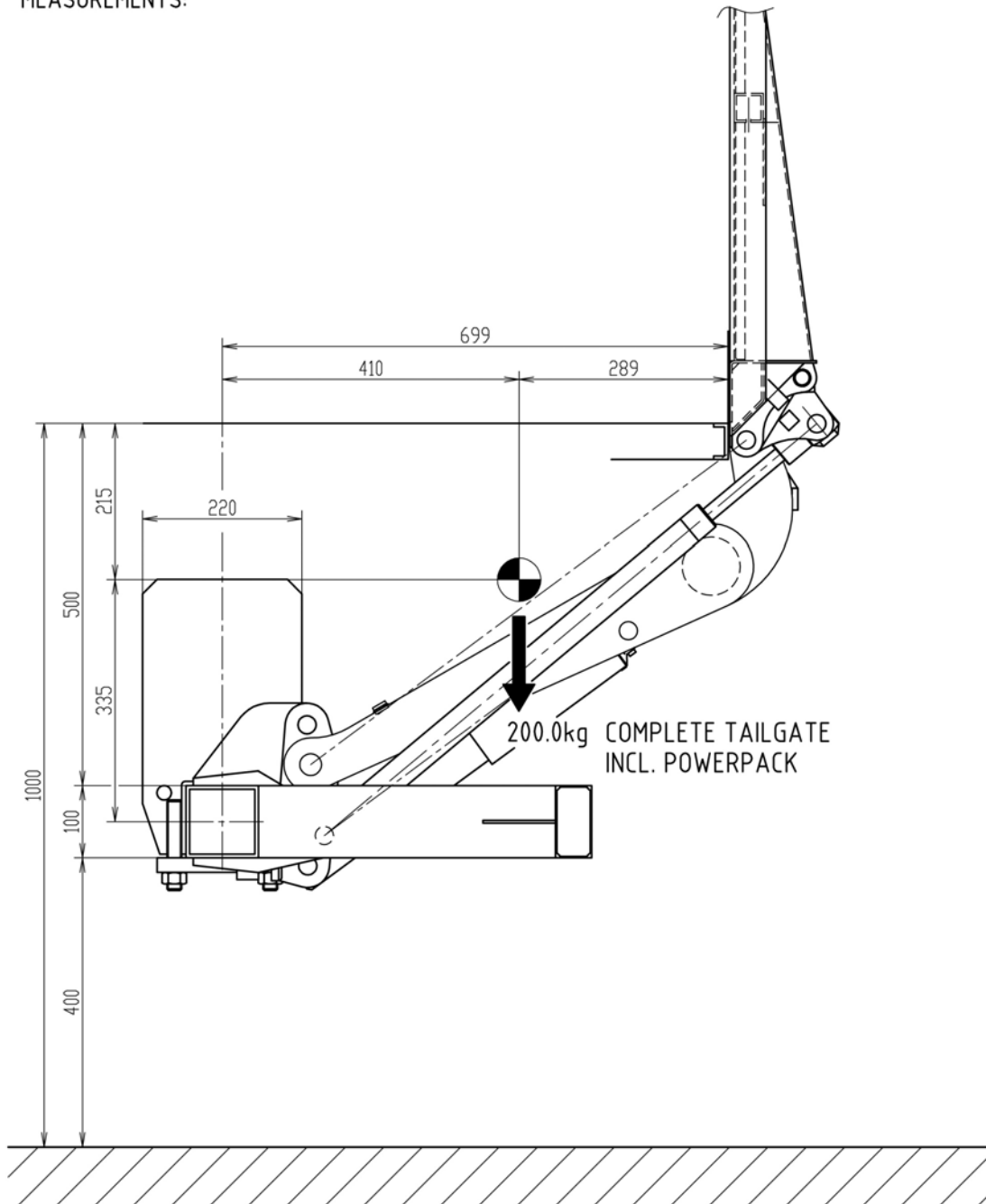

© Copyright by AHT 2006

**MODEL: HTK-500ST/AL**

**BASIC DIMENSIONS**  
for Liftarm: L=750mm and Platform: L=950mm

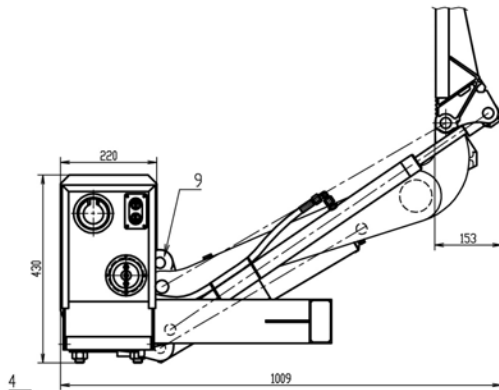

PART No.	PCS.	DESCRIPTION	DRAWING No.	WEIGHT
1	1	CROSS BEAM WITH UNDERRUN BEAM	ATK-750ST-1UFS-MT/500	415kg
2	1	LIFT ARM	ATK-750ST-2L/500	310kg
3	1	PLATFORM ALUMINUM 1750x950	HTK-750AL-3SG	46.0kg
4	2	MOUNTING BRACKET	ATK-750ST-4	14.6kg
5	1 SET	HYDRAULIC HOSE, OIL, * and - CABEL, ADDITIONAL PARTS	HTK-750ST-5	8.0kg
6	1 SET	BOLT ASSEMBLY	HTK-750AL-6	6.6kg
7	1	LEVER ARM	ATK-750ST-7L	4.0kg
8	2	JOINT PLATE	ATK-750AL/G-8L(R)	1.0kg
9	2	TILTING BRACKET	ATK-750AL/G-9L(R)	1.7kg
10	1	TORSION SPRING	ATK-750-10R	1.2kg
11	1	SLIDING BRACKET FOR POWER PACK	UTK-750ST-14	5.7kg
12	2	LIFT CYLINDER Ø35 with mech. hose burst valve	HZ-500AL-35M *	5.4kg
13	1	POWER PACK	MHW-TK-500	9.8kg
14	1	CLOSING CYLINDER	PS-20/140	3.0kg
1	1	[CROSS BEAM WITHOUT UNDERRUN BEAM ATK-750ST-1-MT/500 24.7kg]**		

\* OPTION: with electrical hose burst valve (HZ-500AL-35E) **TOTAL WEIGHT 179.5kg**  
**\*\*TOTAL WEIGHT WITHOUT UNDERRUN BEAM 162.7kg**

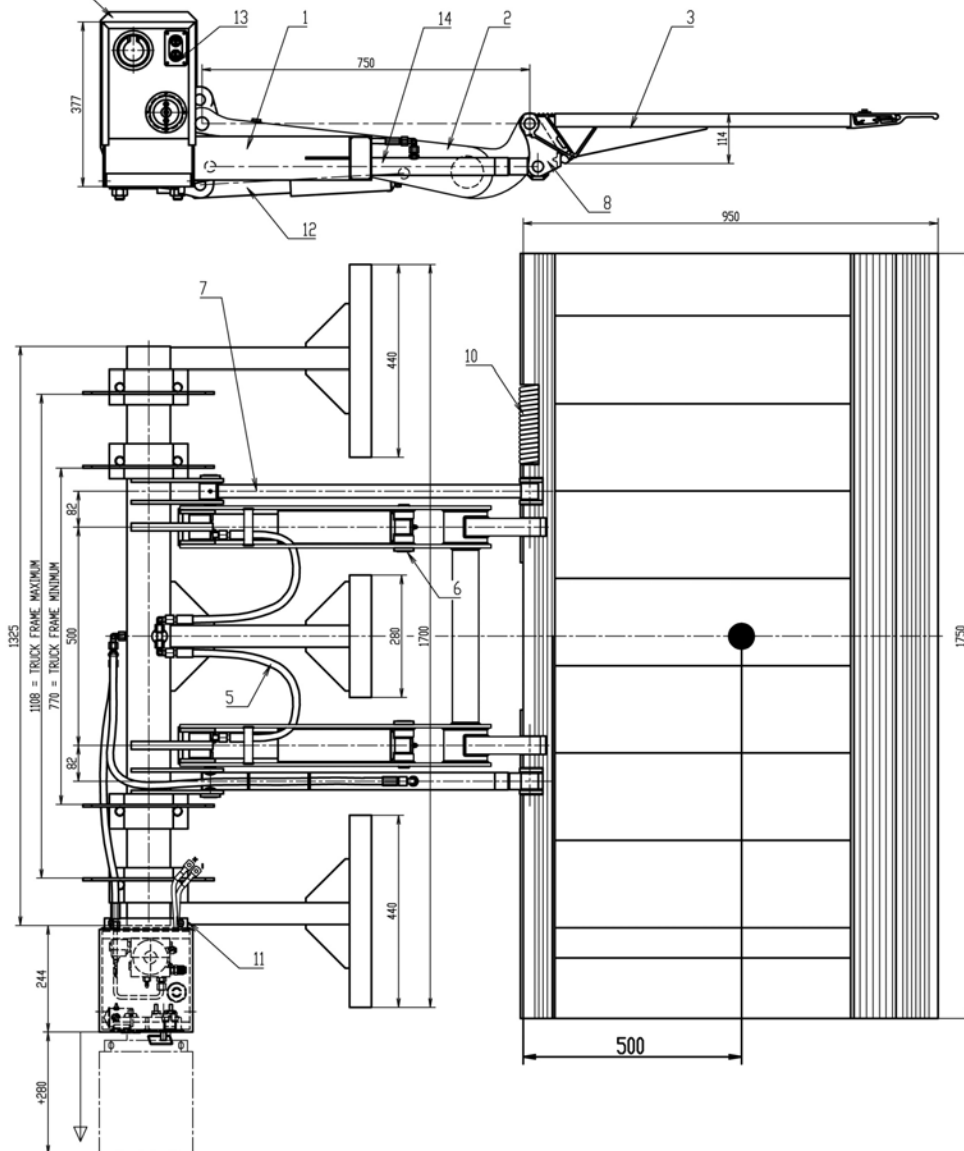

© Copyright by AHT 2006

MODEL: HTK-500ST/AL

# TAILGATE KINEMATICS

for Liftarm: L=750mm and Platform: L=950mm



## MINIMUM MEASUREMENTS

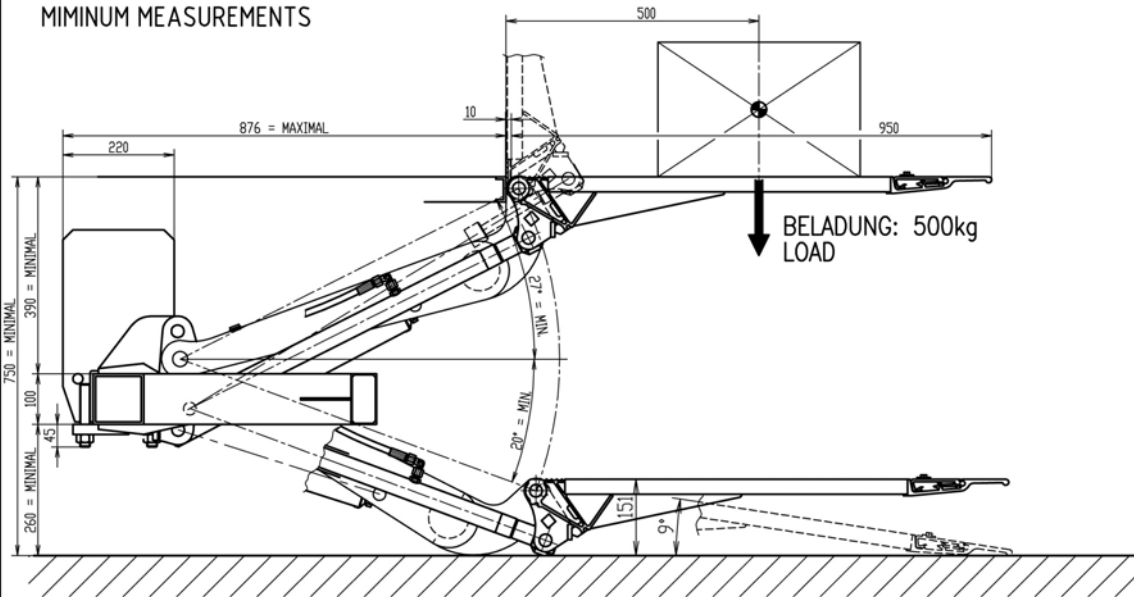

## MAXIMUM MEASUREMENTS

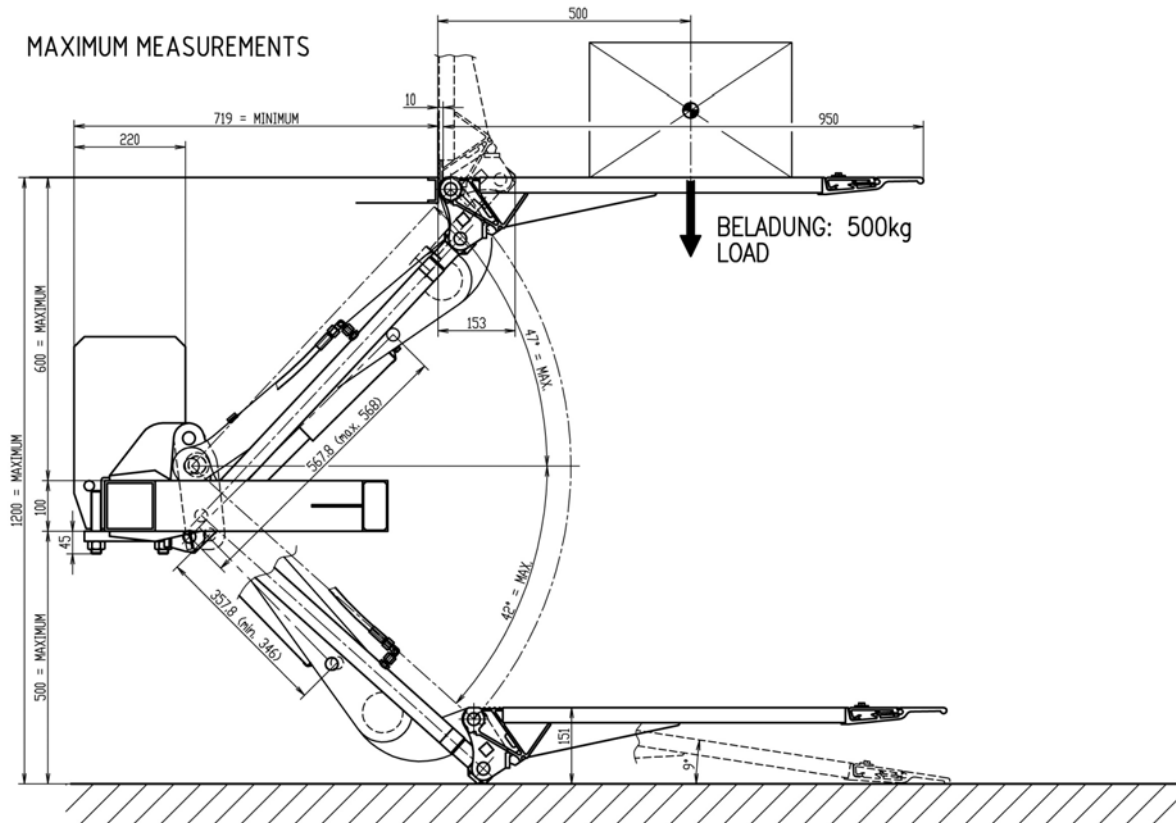

© Copyright by AHT 2006

**MODEL: HTK-500ST/AL****TAILGATE SPECIFICATIONS**

for Liftarm: L=750mm and Platform: L=950mm

**STANDARD SPECIFICATIONS**

CAPACITY kg	<b>500kg at 500mm Gravity Center</b>
NOMINAL PLATFORM SIZE mm	1750 Width x 950 Length x 114 Depth
INSTALLED WEIGHT kg	179.5
FITTING REQUIREMENTS mm	1200 Max. Height Unloaded 750 Min. Height Loaded 720 Min. Underbody Clearance Required*
ADDS TO VEHICLE mm	153

**OTHER SPECIFICATIONS**

<b>WEIGHT</b>	Unit & Cylinder kg	171.5	
	Installation Kit kg	8	
<b>PLATFORM</b>	Aluminum Extrusion Profile	30mm thick	
	Trolley Stops	Option	
	Platform Angle	16.0% or 9'	
<b>LIFT ARM</b>	Construction	2x8mm Steel Plate 40mm Steel Plate on the Platformside	
	Arm Depth mm	96	
	Arm Length mm	750	
	Re-Bushable	Yes	
	Overall width mm	596	
<b>MAIN FRAME</b>	Construction	100mm x 100mm x 5	
	Bracket Thickness mm	6	
<b>PINS</b>	Material	Ø25; Ø30mm Hard Chrome Plated	
	Grease Nipples	Yes	
	Pinlock and Screws	Stainless steel	
<b>BUSHES</b>		Steel Teflon Coated	
<b>HYDRAULIC</b>	Power Pack	M.H.W.	
	Weather Proof Alum Enclosure and Sound Proof	Included	
	Motor Size	0.8kW	
	Lift Cylinders:	Quantity	Two (2) Lift
		Size	Ø35mm; max. Stroke:222mm
		Quality	Cylinder are all Aluminium Piston are all Ceramic plated and Teflon Sealed for Long Life
	Hose Burst Valve	one mechanical hose burst valve on each Cylinder	
	Closing Cylinders:	Quantity	One (1) Closing
		Size	Ø20mm; max. Stroke:140mm
		Quality	Cylinder Tube is made from Aluminum Piston is made from Steel; Hard Chrome plated and Teflon Sealed for Long Life
	Leak Proof Check Valve	Included	
	Hoses	Ø6mm (1/4") Thermo Plastic 2pcs. L=750mm; 2pcs. L=1000mm	
Flow Control	Pressure Compensating		
Oil Type	Hydraulic Oil 22cSt		
<b>OPERATION</b>	Lift Operation	Power up/Gravity down	
	Tilting Operation	automatical mechanical Tilting on the ground floor	
	Closing Operation	automatical hydraulic Closing at Truck Floor Level	
	Locking Device	Platform Lock	
<b>CONROLS</b>	Battery Isolation Switch	Integral to Power Pack	
	Fixed Control	2 Button on Power Pack	
	Removable Remote Push Button	2 Button Hand Held c/w 3m Lead	
	Safety Plug	Yes	
	Base	Yes (Flush Mounted)	

© Copyright by AHT 2006

\* Subject to Vehicle Type &amp; Floor Height

MODEL: HTK-500ST/AL

# TAILGATE KINEMATICS

for Liffarm: L=750mm and Platform: L=950mm



## CENTRE OF MASS FOR HTK-500ST/AL IN TRAVELING POSITION

MEASUREMENTS:

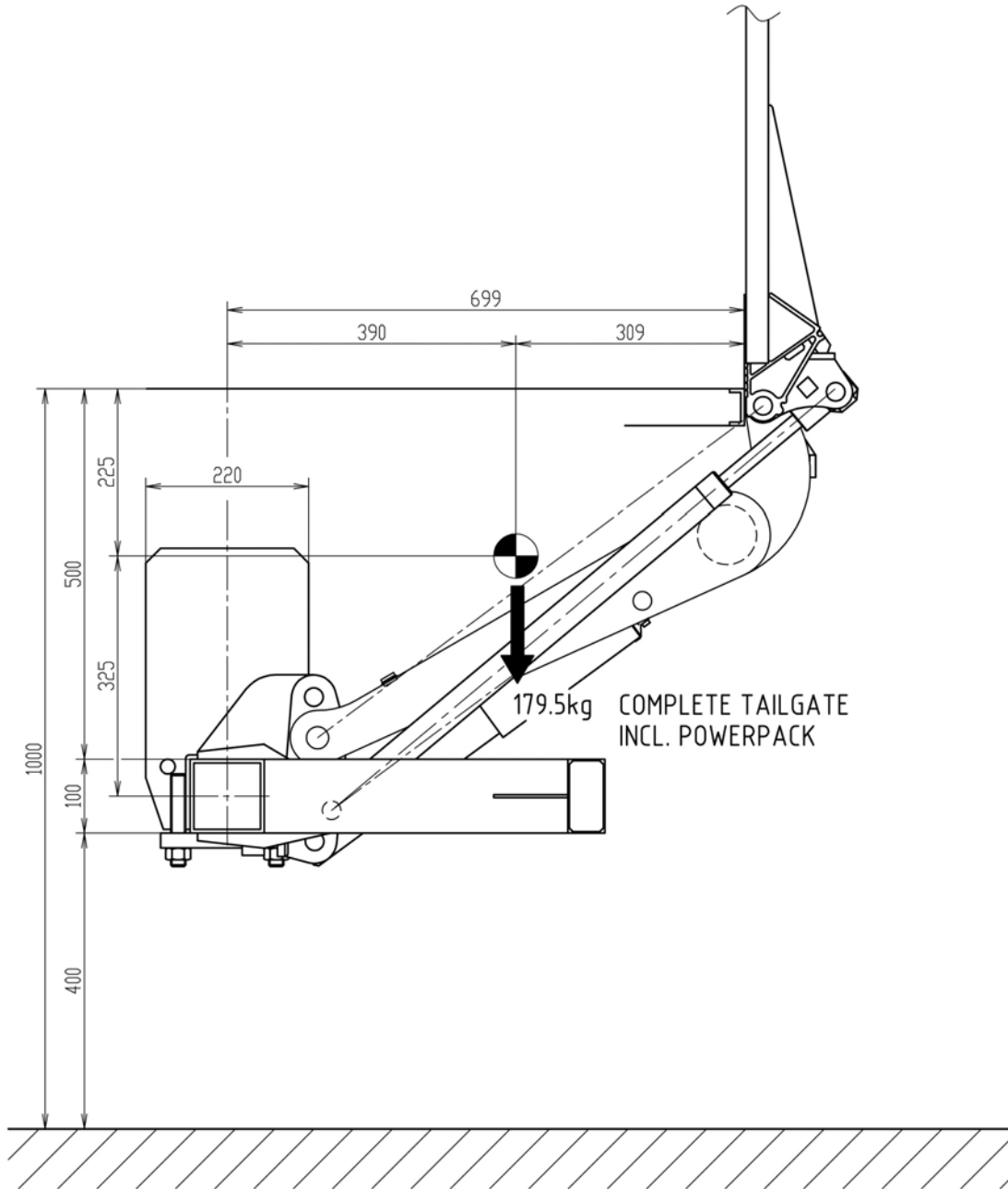

© Copyright by AHT 2006



**MODEL: HTK-750ST/M**

**BASIC DIMENSIONS**  
for Liftarm: L=750mm and Platform: L=950mm

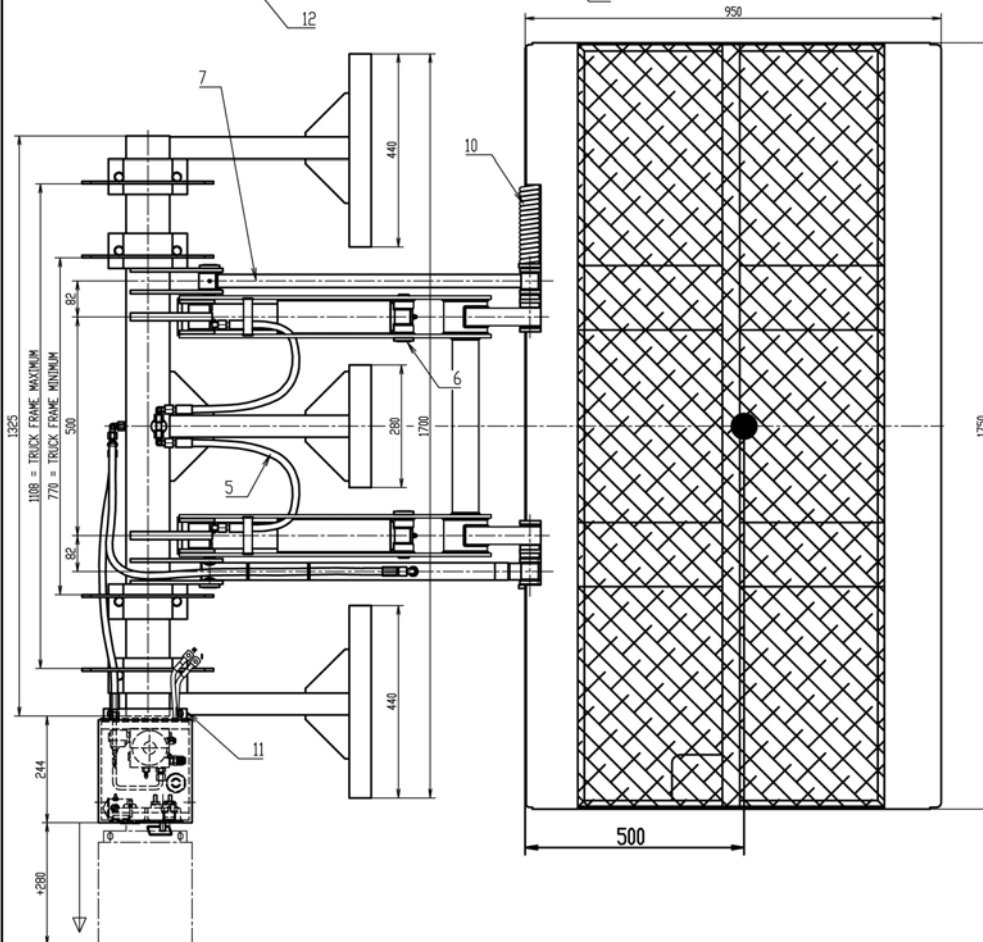
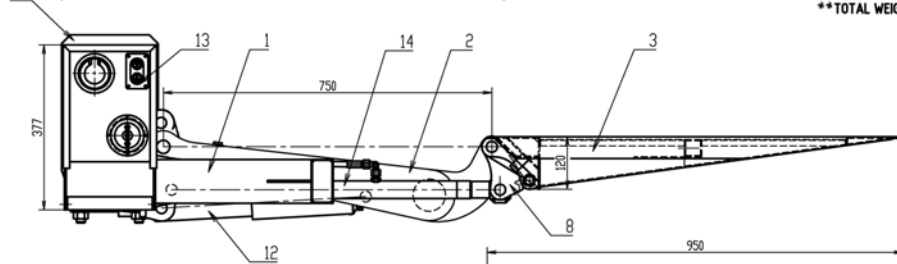
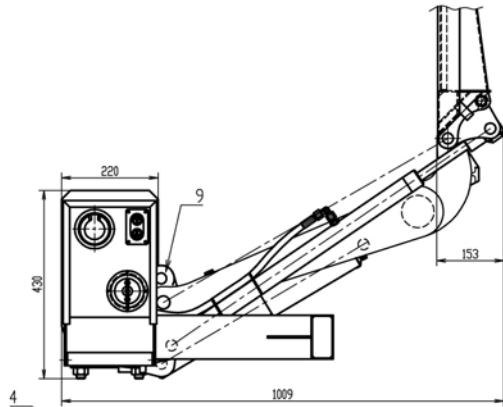

PART No.	PCS.	DESCRIPTION	DRAWING No.	WEIGHT
1	1	CROSS BEAM WITH UNDERRUN BEAM	ATK-750ST-1UFS-MT/500	415kg
2	1	LIFT ARM	ATK-750ST-2L/500	310kg
3	1	PLATFORM WITH MESH 1750x950	HTK-750ST-3SG	66.5kg
4	2	MOUNTING BRACKET	ATK-750ST-4	14.6kg
5	1 SET	HYDRAULIC HOSE, OIL, * and - CABEL, ADDITIONAL PARTS	HTK-750ST-5	8.0kg
6	1 SET	BOLT ASSEMBLY	HTK-750AL-6	6.6kg
7	1	LEVER ARM	ATK-750ST-7L	4.0kg
8	2	JOINT PLATE	ATK-750AL/G-8L(R)	1.0kg
9	2	TILTING BRACKET	ATK-750AL/G-9L(R)	1.7kg
10	1	TORSION SPRING	ATK-750-10R	1.2kg
11	1	SLIDING BRACKET FOR POWER PACK	UTK-750ST-14	5.7kg
12	2	LIFT CYLINDER Ø42 with mech. hose burst valve	HZ-750AL-42M *	5.9kg
13	1	POWER PACK	MHW-TK-750	9.8kg
14	1	CLOSING CYLINDER	PS-20/140	3.0kg
1	1	[CROSS BEAM WITHOUT UNDERRUN BEAM ATK-750ST-1-MT/500 24.7kg]**		

\* OPTION: with electrical hose burst valve (HZ-750AL-42E) **TOTAL WEIGHT 200.5kg**

\*\*TOTAL WEIGHT WITHOUT UNDERRUN BEAM **183.7kg**

© Copyright by AHT 2006

MODEL: HTK-750ST/M

# TAILGATE KINEMATICS

for Liftarm: L=750mm and Platform: L=950mm



## MINIMUM MEASUREMENTS

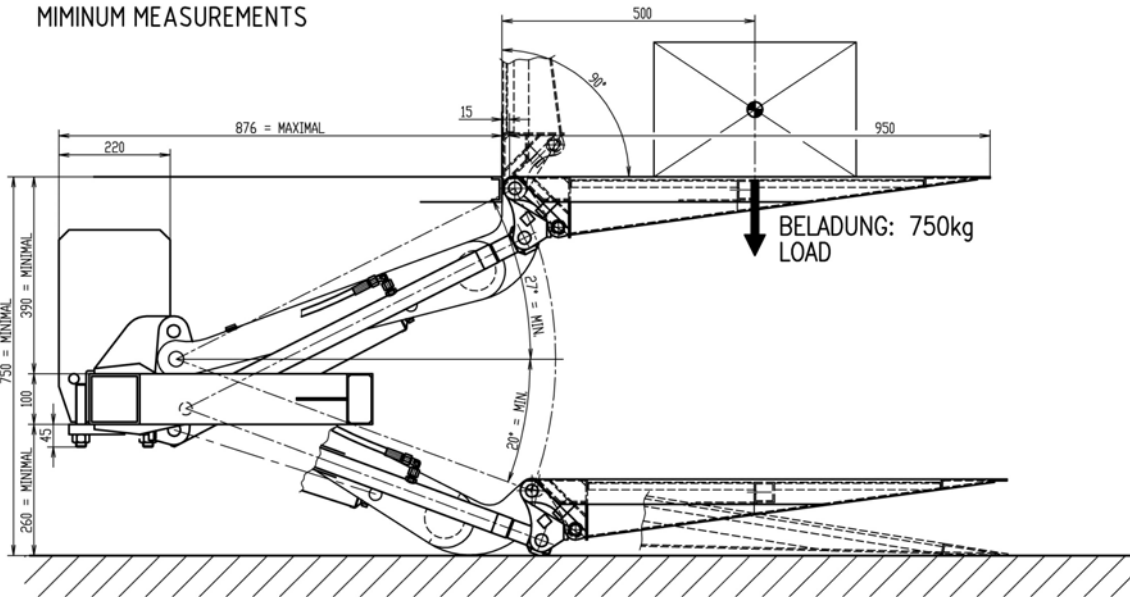

## MAXIMUM MEASUREMENTS

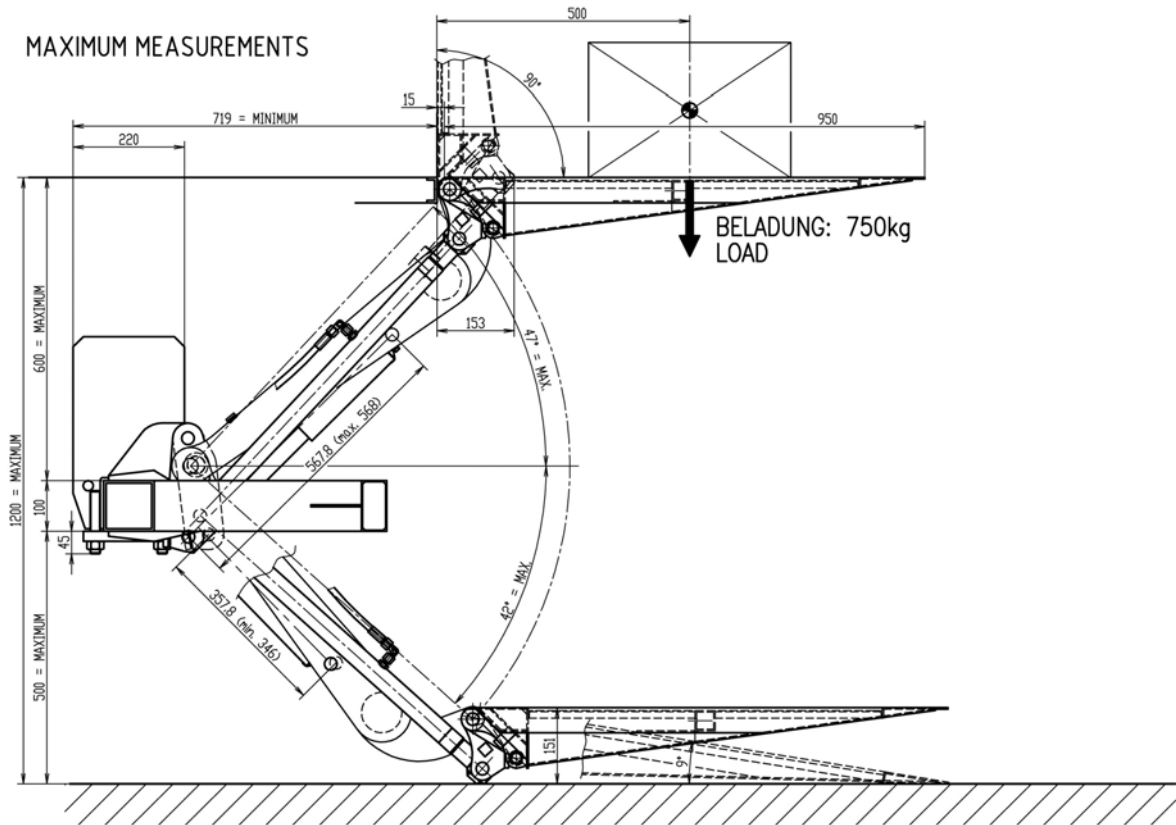

© Copyright by AHT 2006

**MODEL: HTK-750ST/M****TAILGATE SPECIFICATIONS**

for Liftarm: L=750mm and Platform: L=950mm

**STANDARD SPECIFICATIONS**

CAPACITY kg	<b>750kg at 500mm Gravity Center</b>
NOMINAL PLATFORM SIZE mm	1750 Width x 950 Length x 120 Depth
INSTALLED WEIGHT kg	200.5
FITTING REQUIREMENTS mm	1200 Max. Height Unloaded 750 Min. Height Loaded 720 Min. Underbody Clearance Required*
ADDS TO VEHICLE mm	153

**OTHER SPECIFICATIONS**

<b>WEIGHT</b>	Unit & Cylinder kg	192.5
	Installation Kit kg	8
<b>PLATFORM</b>	Platform with Mesh	Welded Steel Construction (Galvanized)
	Mesh	~62x25; Cross-Section 6x3
	Trolley Stops	No
	Platform Angle	16.0% or 9'
<b>LIFT ARM</b>	Construction	2x8mm Steel Plate 40mm Steel Plate on the Platformside
	Arm Depth mm	96
	Arm Length mm	750
	Re-Bushable	Yes
	Overall width mm	596
	<b>MAIN FRAME</b>	Construction
	Bracket Thickness mm	6
<b>PINS</b>	Material	Ø25; Ø30mm Hard Chrome Plated
	Grease Nipples	Yes
	Pinlock and Screws	Stainless steel
<b>BUSHES</b>		Steel Teflon Coated
<b>HYDRAULIC</b>	Power Pack	M.H.W.
	Weather Proof Alum Enclosure and Sound Proof	Included
	Motor Size	0.8kW
	Lift Cylinders: Quantity	Two (2) Lift
	Size	Ø42mm; max. Stroke:222mm
	Quality	Cylinder are all Aluminium Piston are all Ceramic plated and Teflon Sealed for Long Life
	Hose Burst Valve	one mechanical hose burst valve on each Cylinder
	Closing Cylinders: Quantity	One (1) Closing
	Size	Ø20mm; max. Stroke:140mm
	Quality	Cylinder Tube is made from Aluminum Piston is made from Steel; Hard Chrome plated and Teflon Sealed for Long Life
	Leak Proof Check Valve	Included
	Hoses	Ø6mm (1/4") Thermo Plastic 2pcs. L=750mm; 2pcs. L=1000mm
	Flow Control	Pressure Compensating
Oil Type	Hydraulic Oil 22cSt	
<b>OPERATION</b>	Lift Operation	Power up/Gravity down
	Tilting Operation	automatical mechanical Tilting on the ground floor
	Closing Operation	automatical hydraulic Closing at Truck Floor Level
	Locking Device	Platform Lock
<b>CONROLS</b>	Battery Isolation Switch	Integral to Power Pack
	Fixed Control	2 Button on Power Pack
	Removable Remote Push Button	2 Button Hand Held c/w 3m Lead
	Safety Plug	Yes
	Base	Yes (Flush Mounted)

© Copyright by AHT 2006

\* Subject to Vehicle Type &amp; Floor Height

MODEL: HTK-750ST/M

**TAILGATE KINEMATICS**  
for Liftarm: L=750mm and Platform: L=950mm



**CENTRE OF MASS FOR HTK-750ST/M IN TRAVELING POSITION**

MEASUREMENTS:

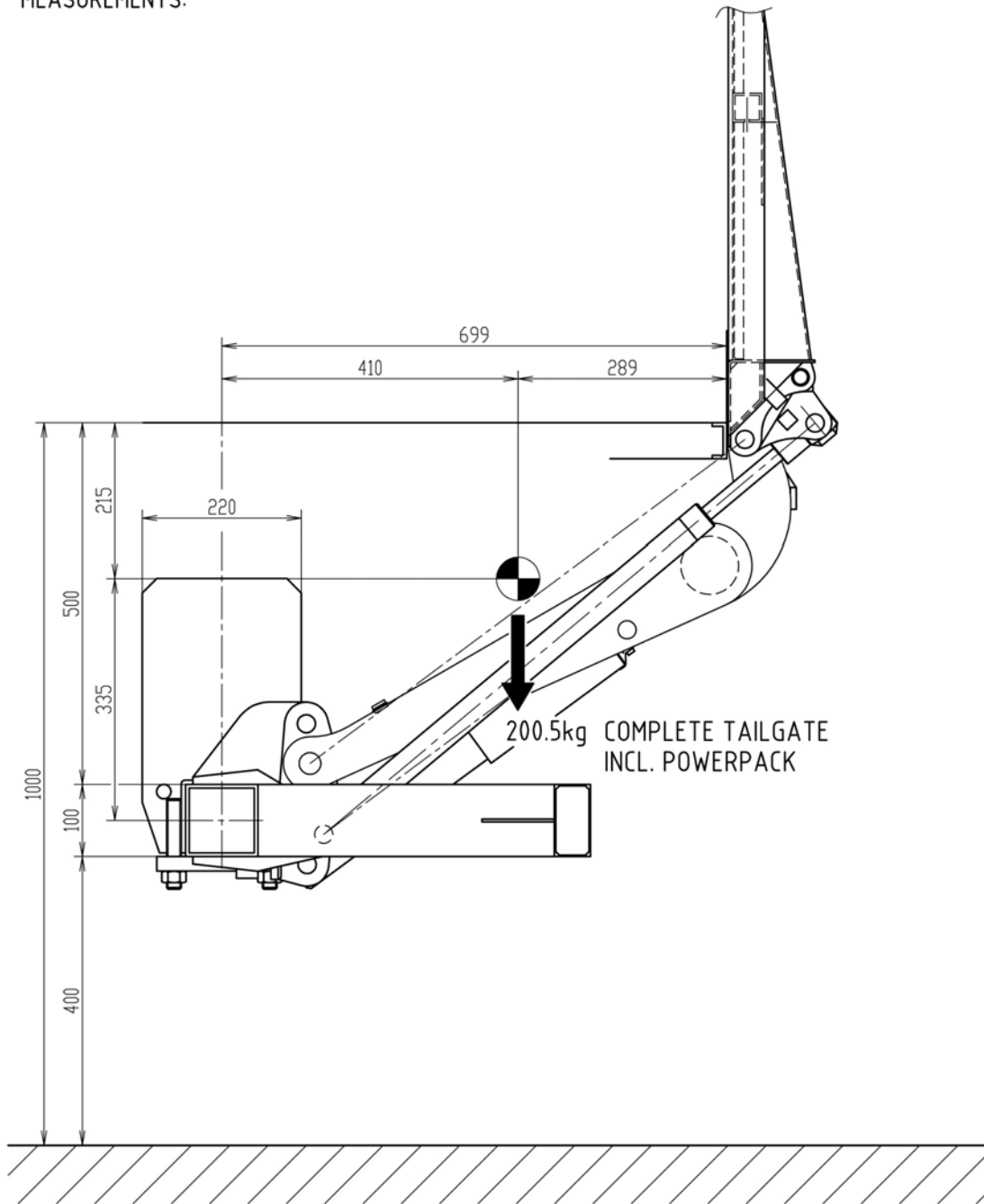

© Copyright by AHT 2006

**MODEL: HTK-750ST/AL**

**BASIC DIMENSIONS**  
for Liftarm: L=750mm and Platform: L=950mm

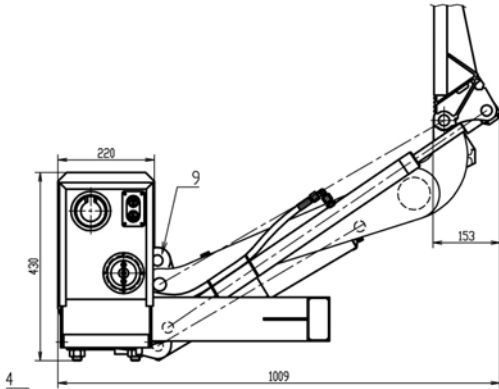

PART No.	PCS.	DESCRIPTION	DRAWING No.	WEIGHT
1	1	CROSS BEAM WITH UNDERRUN BEAM	ATK-750ST-1UFS-MT/500	4.15kg
2	1	LIFT ARM	ATK-750ST-2L/500	31.0kg
3	1	PLATFORM ALUMINUM 1750x950	HTK-750AL-3SG	46.0kg
4	2	MOUNTING BRACKET	ATK-750ST-4	14.6kg
5	1 SET	HYDRAULIC HOSE, OIL, * and - CABEL, ADDITIONAL PARTS	HTK-750ST-5	8.0kg
6	1 SET	BOLT ASSEMBLY	HTK-750AL-6	6.6kg
7	1	LEVER ARM	ATK-750ST-7L	4.0kg
8	2	JOINT PLATE	ATK-750AL/G-8L(R)	1.0kg
9	2	TILTING BRACKET	ATK-750AL/G-9L(R)	1.7kg
10	1	TORSION SPRING	ATK-750-10R	1.2kg
11	1	SLIDING BRACKET FOR POWER PACK	UTK-750ST-14	5.7kg
12	2	LIFT CYLINDER Ø42 with mech. hose burst valve	HZ-750AL-42M *	5.9kg
13	1	POWER PACK	MHW-TK-750	9.8kg
14	1	CLOSING CYLINDER	PS-20/140	3.0kg
1	1	[CROSS BEAM WITHOUT UNDERRUN BEAM ATK-750ST-1-MT/500 24.7kg]**		

\* OPTION: with electrical hose burst valve (HZ-750AL-42E) **TOTAL WEIGHT 180.0kg**  
**\*\*TOTAL WEIGHT WITHOUT UNDERRUN BEAM 163.2kg**

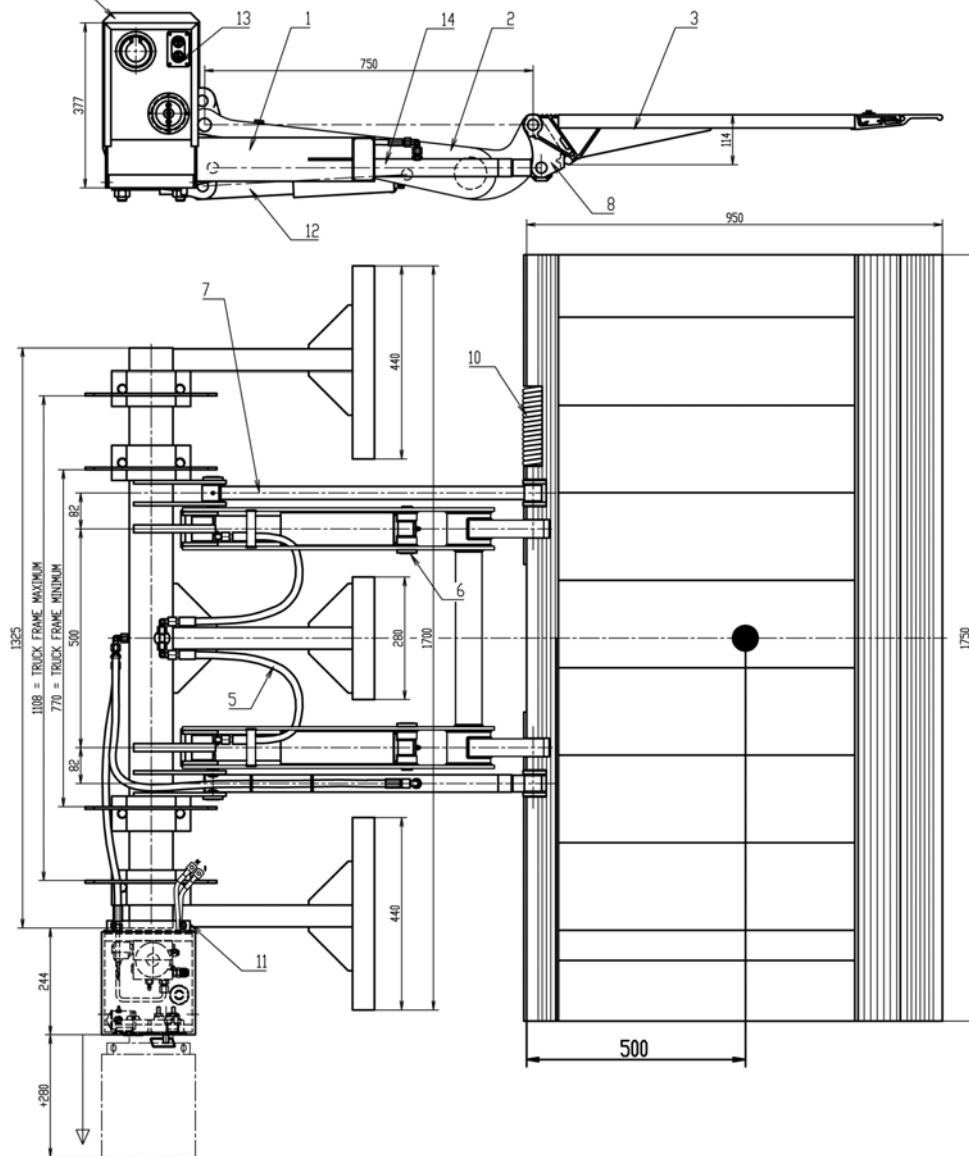

© Copyright by AHT 2006

MODEL: HTK-750ST/AL

# TAILGATE KINEMATICS

for Liftarm: L=750mm and Platform: L=950mm



## MINIMUM MEASUREMENTS

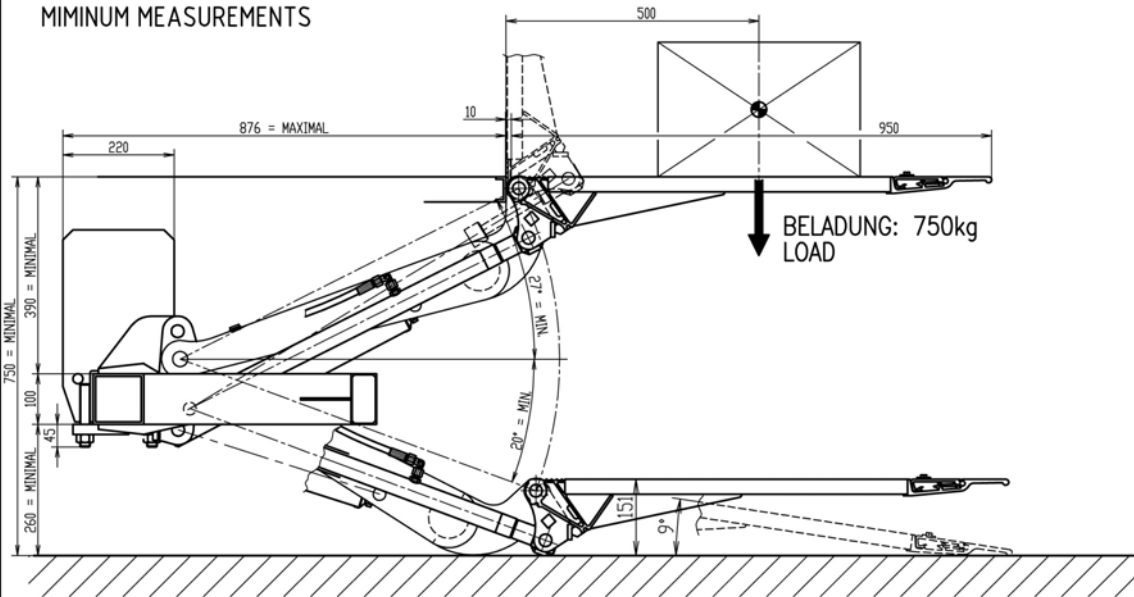

## MAXIMUM MEASUREMENTS

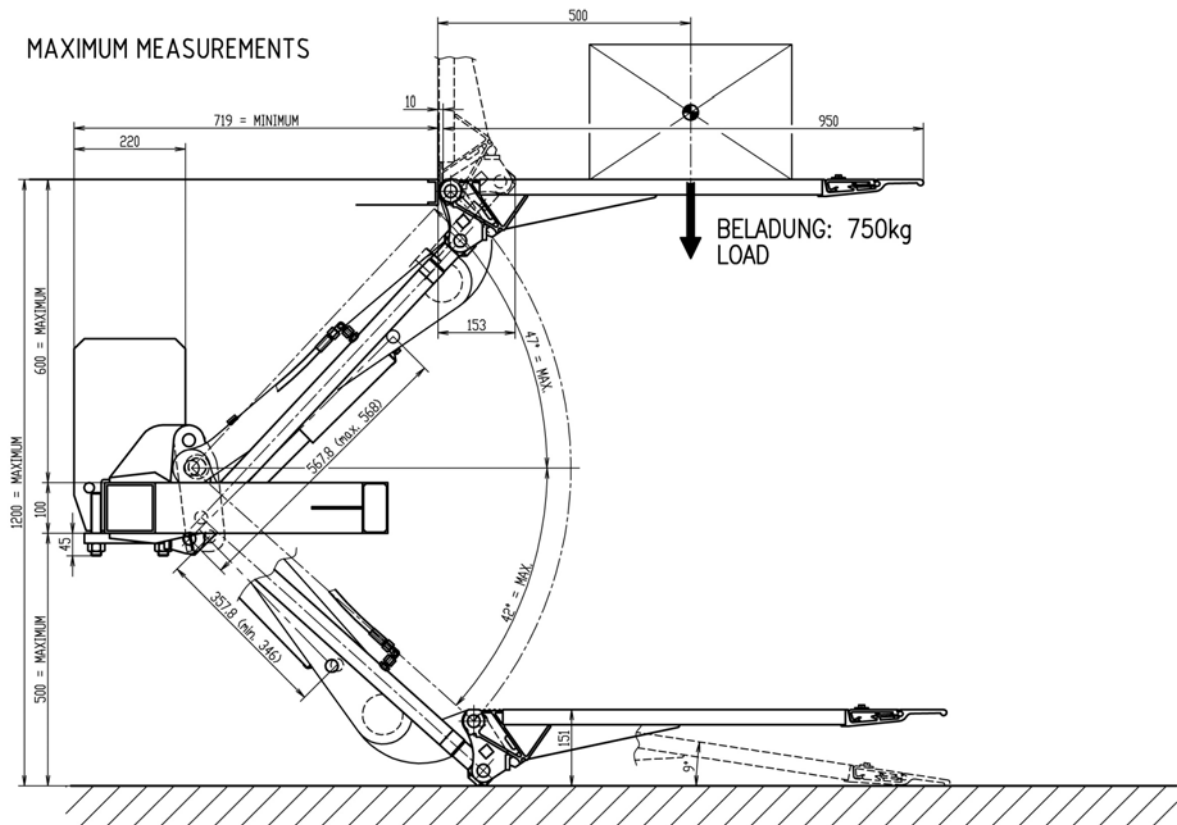

© Copyright by AHT 2006

**MODEL: HTK-750ST/AL****TAILGATE SPECIFICATIONS**

for Liftarm: L=750mm and Platform: L=950mm

**STANDARD SPECIFICATIONS**

CAPACITY kg	<b>750kg at 500mm Gravity Center</b>
NOMINAL PLATFORM SIZE mm	1750 Width x 950 Length x 114 Depth
INSTALLED WEIGHT kg	180
FITTING REQUIREMENTS mm	1200 Max. Height Unloaded 750 Min. Height Loaded 720 Min. Underbody Clearance Required*
ADDS TO VEHICLE mm	153

**OTHER SPECIFICATIONS**

<b>WEIGHT</b>	Unit & Cylinder kg	172	
	Installation Kit kg	8	
<b>PLATFORM</b>	Aluminum Extrusion Profile	30mm thick	
	Trolley Stops	Option	
	Platform Angle	16.0% or 9'	
<b>LIFT ARM</b>	Construction	2x8mm Steel Plate 40mm Steel Plate on the Platformside	
	Arm Depth mm	96	
	Arm Length mm	750	
	Re-Bushable	Yes	
	Overall width mm	596	
<b>MAIN FRAME</b>	Construction	100mm x 100mm x 5	
	Bracket Thickness mm	6	
<b>PINS</b>	Material	Ø25; Ø30mm Hard Chrome Plated	
	Grease Nipples	Yes	
	Pinlock and Screws	Stainless steel	
<b>BUSHES</b>		Steel Teflon Coated	
<b>HYDRAULIC</b>	Power Pack	M.H.W.	
	Weather Proof Alum Enclosure and Sound Proof	Included	
	Motor Size	0.8kW	
	Lift Cylinders:	Quantity	Two (2) Lift
		Size	Ø42mm; max. Stroke:222mm
		Quality	Cylinder are all Aluminium Piston are all Ceramic plated and Teflon Sealed for Long Life
	Hose Burst Valve	one mechanical hose burst valve on each Cylinder	
	Closing Cylinders:	Quantity	One (1) Closing
		Size	Ø20mm; max. Stroke:140mm
		Quality	Cylinder Tube is made from Aluminum Piston is made from Steel; Hard Chrome plated and Teflon Sealed for Long Life
	Leak Proof Check Valve	Included	
	Hoses	Ø6mm (1/4") Thermo Plastic 2pcs. L=750mm; 2pcs. L=1000mm	
	Flow Control	Pressure Compensating	
Oil Type	Hydraulic Oil 22cSt		
<b>OPERATION</b>	Lift Operation	Power up/Gravity down	
	Tilting Operation	automatical mechanical Tilting on the ground floor	
	Closing Operation	automatical hydraulic Closing at Truck Floor Level	
	Locking Device	Platform Lock	
<b>CONROLS</b>	Battery Isolation Switch	Integral to Power Pack	
	Fixed Control	2 Button on Power Pack	
	Removable Remote Push Button	2 Button Hand Held c/w 3m Lead	
	Safety Plug	Yes	
	Base	Yes (Flush Mounted)	

© Copyright by AHT 2006

\* Subject to Vehicle Type &amp; Floor Height

MODEL: HTK-750ST/AL

# TAILGATE KINEMATICS

for Liftarm: L=750mm and Platform: L=950mm



## CENTRE OF MASS FOR HTK-750ST/AL IN TRAVELING POSITION

MEASUREMENTS:

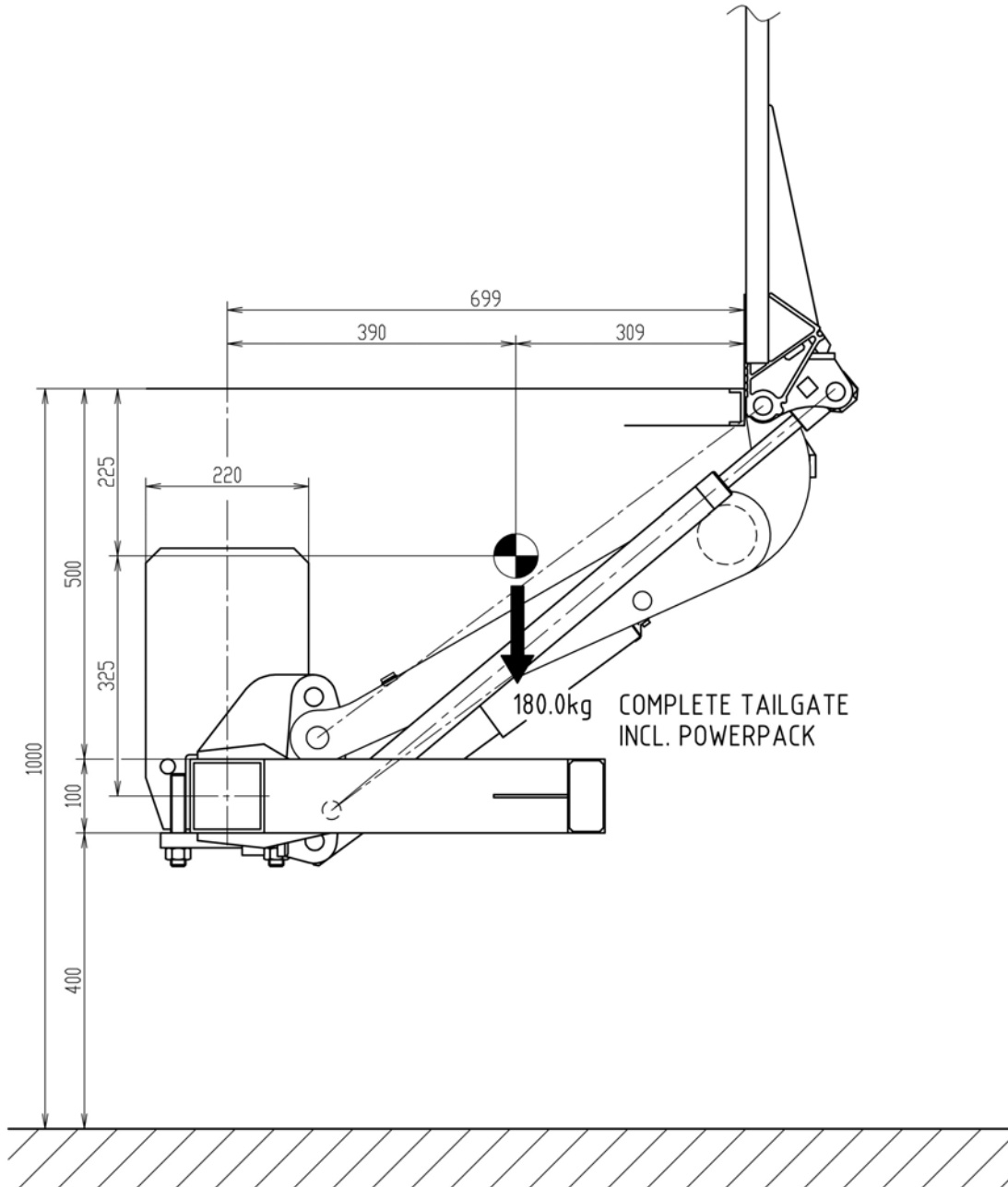

© Copyright by AHT 2006



# ELECTRIC AND HYDRAULIC DIAGRAM

with mechanical hose burst valve  
with 2-Button-Remote-Control  
with 2-Button-Hand-Control

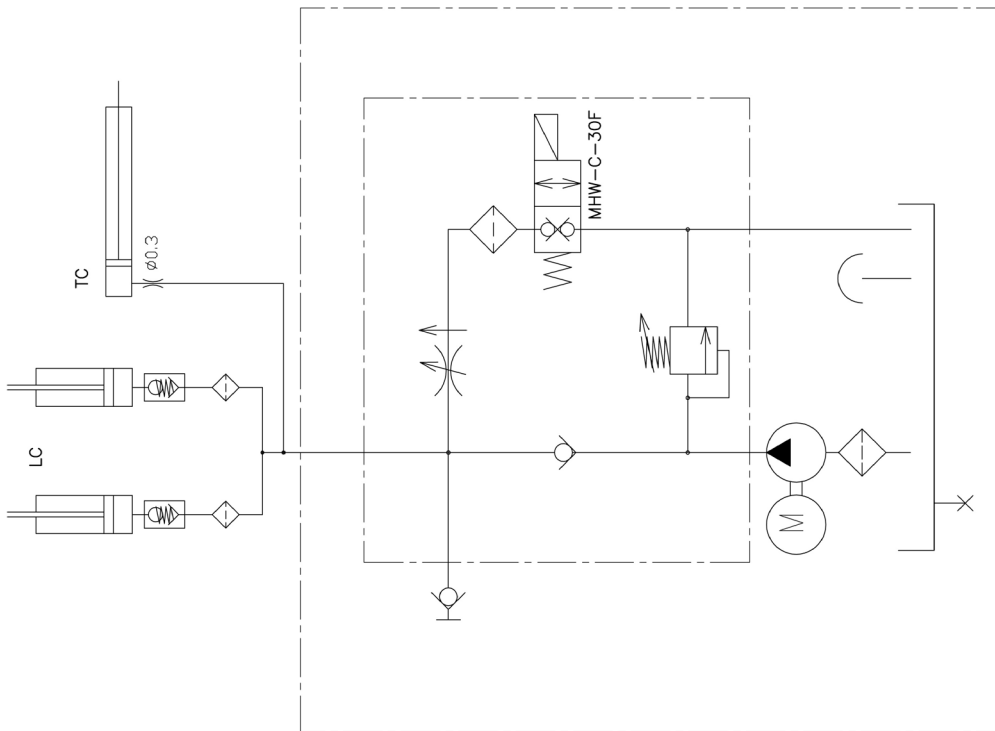
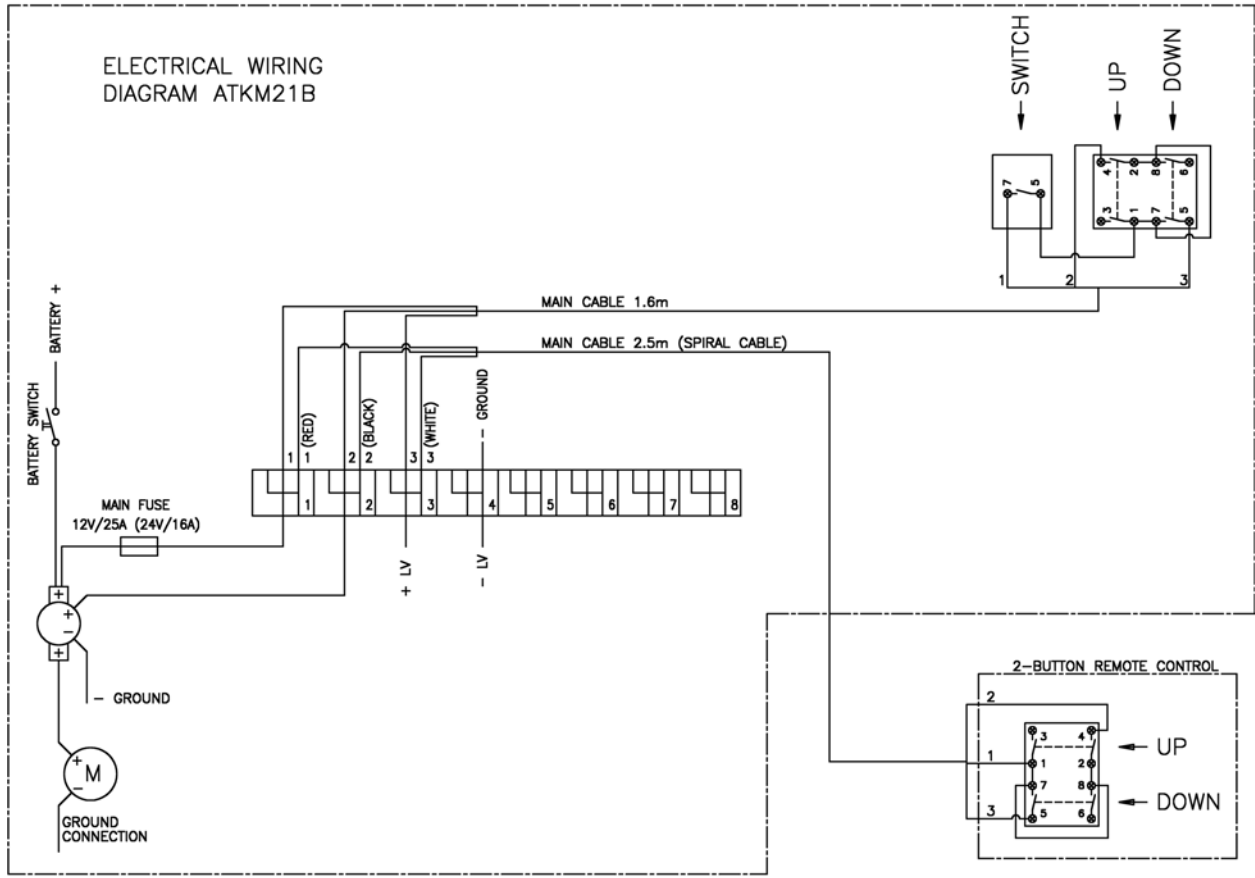

# I N D E X

	Page
Service qualifications	2
Installation guidelines	2
Unpacking the tailgate loader	3
Preparing for installation	4
Installing the mounting device	5
Position the tailgate unit	6 - 7
Energize the power pack	8
Correct wiring of power pack	9
Installing the platform	10 - 13
Remove tilting lock	14
How to adjust the platform level	15
Installing a platform lock	16
Basic dimensions (HTK-500ST/M)	17
Tailgate Schematics (HTK-500ST/M)	18
Tailgate Specification (HTK-500ST/M)	19
Centre of Mass (HTK-500ST/M)	20
Basic dimensions (HTK-500ST/AL)	21
Tailgate Schematics (HTK-500ST/AL)	22
Tailgate Specification (HTK-500ST/AL)	23
Centre of Mass (HTK-500ST/AL)	24
Basic dimensions (HTK-750ST/M)	25
Tailgate Schematics (HTK-750ST/M)	26
Tailgate Specification (HTK-750ST/M)	27
Centre of Mass (HK-750ST/M)	28
Basic dimensions (HTK-750ST/AL)	29
Tailgate Schematics (HTK-750ST/AL)	30
Tailgate Specification (HTK-750ST/AL)	31
Centre of Mass (HTK-750ST/AL)	32
Electric and hydraulic diagram	33